



**DODSON  
GLOBALINC**



<b>Weld Fittings Section.....</b>	<b>3</b>
<b>Standard Wall</b>	
WeldELLS 90° & 45° .....	5
WeldELLS 3R & Reducing 90s.....	6
Tees – Straight & Reducing .....	7
Reducers – Concentric & Eccentric.....	9
Stub ends, Caps, 180° Returns.....	10
Crosses – Straight & Reducing .....	11
45° Laterals – Straight & Reducing .....	12
<b>Extra Heavy Wall</b>	
WeldELLS 90° & 45.....	15
WeldELLS 3R & Reducing 90s.....	16
Tees – Straight & Reducing .....	17
Reducers – Concentric & Eccentric.....	19
Stub ends, Caps, 180° Returns.....	20
Crosses – Straight & Reducing .....	21
45° Laterals – Straight & Reducing .....	22
<b>Flanges Section.....</b>	<b>23</b>
AWWA C207-94 Class D Steel Ring Flanges.....	25
150lb .....	26
300lb .....	28
400lb .....	30
600lb .....	32
900lb .....	34
1500lb .....	36
2500lb .....	38
Series A/MSS SP44 Class 150 .....	40
Series A/MSS SP44 Class 300 .....	41
Series A/MSS SP44 Class 400 .....	42
Series A/MSS SP44 Class 600 .....	43
Series A/MSS SP44 Class 900 .....	44
Series B/API 605 Class 75.....	45
Series B/API 605 Class 150 .....	47
Series B/API 605 Class 300 .....	48
Series B/API 605 Class 400 & 600.....	49
Series B/API 605 Class 900 .....	50
AWWA C207-07 Class B Ring .....	51
AWWA C207-94 Class B Hub.....	52
AWWA C207-07 Class D Ring.....	53
AWWA C207-07 Class D Hub.....	54
AWWA C207-07 Class E Hub.....	55
AWWA C207-07 Class E Ring.....	56
AWWA C207-07 Class F Ring.....	57
AWWA C207-07 Class B Blind .....	58
AWWA C207-07 Class D Blind.....	59
AWWA C207-07 Class E Blind.....	60
AWWA C207-07 Class F Blind.....	61

continued on next page



**Technical Section..... 63**  
Dimensional Tolerances for Welding Fittings ..... 65  
Methods of Attachment for Standard Types of Flanges ..... 66  
Dimensional Tolerances for Forged Steel Flanges..... 67  
American Standard Flange Facings..... 68  
Facing Dimensions for Ring Joint Flanges..... 70  
Threading Practice for American Standard Flanges..... 73  
Allowable Working Pressures Tabulated ..... 75  
Pressure Temperature Ratings of Flanges..... 76  
Dimensions of Seamless & Welded Pipe..... 80  
Decimal & Metric Equiv. to Fractions / API vs ANSI Flange Dimensions..... 82

**Forged Steel Section ..... 83**  
Threaded Fittings ..... 85  
Threaded Couplings, Reducers & Caps ..... 86  
Threaded Plugs & Bushings..... 87  
Socket Weld Fittings..... 88  
Socket Weld Couplings, Reducers & Caps..... 89  
Socket Weld Reducer Inserts ..... 90  
MSS-SP-83 Unions – Threaded & Socket Weld ..... 91

**Olets Section..... 93**  
Flexolet..... 95  
Latrolet..... 98  
Elbolet..... 99  
Nipolet..... 100  
Flexolet Run Size Combinations..... 101

# Standard Wall



# WeldELLS—90° and 45°

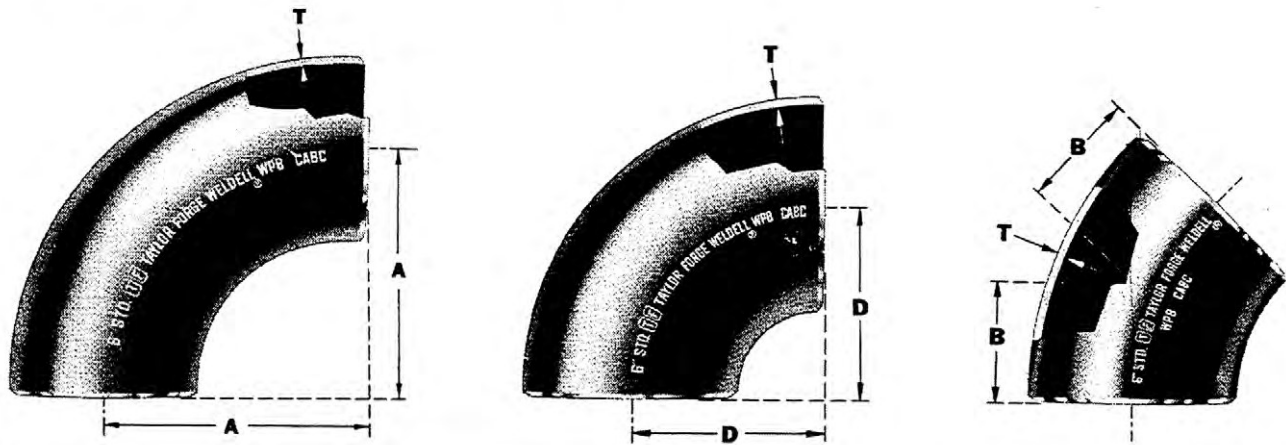

Nominal Pipe Size	90° WeldELLS				45° WeldELLS		DIMENSIONS COMMON TO FITTINGS AND PIPE			
	LONG RADIUS		SHORT RADIUS		Center to End B	Approx Weight Pounds	Nominal Pipe Size	Outside Diameter	Inside Diameter	Wall Thickness
	Center to End A	Approx Weight Pounds	Center to End D	Approx Weight Pounds						
1/2	1 1/2	.17	--	--	3/8	.09	1/2	.840	.622	.109
3/4	1 1/4	.17	--	--	3/8	.09	3/4	1.050	.824	.113
1	1 1/2	.34	1	.23	3/8	.17	1	1.315	1.049	.133
1 1/4	1 3/8	.58	1 1/4	.39	1	.29	1 1/4	1.660	1.380	.140
1 1/2	2 1/4	.84	1 1/2	.56	1 1/8	.42	1 1/2	1.900	1.610	.145
2	3	1.50	2	1.00	1 3/8	.75	2	2.375	2.067	.154
2 1/2	3 3/4	2.98	2 1/2	1.98	1 3/4	1.49	2 1/2	2.875	2.469	.203
3	4 1/2	4.68	3	3.12	2	2.34	3	3.500	3.068	.216
3 1/2	5 1/4	6.56	3 1/2	4.38	2 1/4	3.28	3 1/2	4.000	3.548	.226
4	6	8.9	4	5.9	2 1/2	4.45	4	4.500	4.026	.237
5	7 1/2	15.1	5	10.1	3 1/8	7.55	5	5.563	5.047	.258
6	9	23.5	6	15.6	3 3/8	11.80	6	6.625	6.065	.280
8	12	47	8	31.4	5	23.5	8	8.625	7.981	.322
10	15	83	10	55.7	6 1/4	41.8	10	10.750	10.020	.365
12	18	123	12	81.9	7 1/2	61.5	12	12.750	12.000	.375
14	21	158	14	105	8 3/4	79	14	14.000	13.250	.375
16	24	207	16	138	10	104	16	16.000	15.250	.375
18	27	263	18	175	11 1/4	132	18	18.000	17.250	.375
20	30	323	20	215	12 1/2	162	20	20.000	19.250	.375
22	33	392	--	--	13 1/2	196	22	22.000	21.250	.375
24	36	468	24	313	15	234	24	24.000	23.250	.375
26	39	550	--	--	16	275	26	26.000	25.250	.375
30	45	733	30	488	18 1/2	367	30	30.000	29.250	.375
36†	54	1061	36	707	22 1/4	531	36	36.000	35.250	.375
42†	63	1442	48	1079	26	721	42	42.000	41.250	.375

All dimensions are in inches.



## WeldELLS

90° Reducing

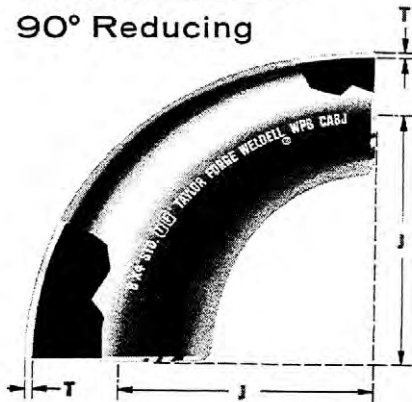

All dimensions are in inches.

Nominal Pipe Size	Center to End	Approx Weight Pounds
	J	
2 x 1½	3	1.50
2 x 1¼	3	1.37
2 x 1	3	1.25
2½ x 2	3¾	2.75
2½ x 1½	3¾	2.50
2½ x 1¼	3¾	2.25
3 x 2½	4½	4.25
3 x 2	4½	4.00
3 x 1½	4½	3.75
3½ x 3	5¼	6.00
3½ x 2½	5¼	5.50
3½ x 2	5¼	5.00
4 x 3½	6	8.50
4 x 3	6	8.00
4 x 2½	6	7.50
4 x 2	6	7.00

*continued in next table*

Nominal Pipe Size	Center to End	Approx Weight Pounds
	J	
5 x 4	7½	14.0
5 x 3½	7½	13.0
5 x 3	7½	12.0
5 x 2½	7½	11.0
6 x 5	9	21.0
6 x 4	9	20.0
6 x 3½	9	19.0
6 x 3	9	17.5
8 x 6	12	40.0
8 x 5	12	37.5
8 x 4	12	35.0
10 x 8	15	76
10 x 6	15	67
10 x 5	15	62
12 x 10	18	110
12 x 8	18	102
12 x 6	18	90

## WeldELLS

3R 90°

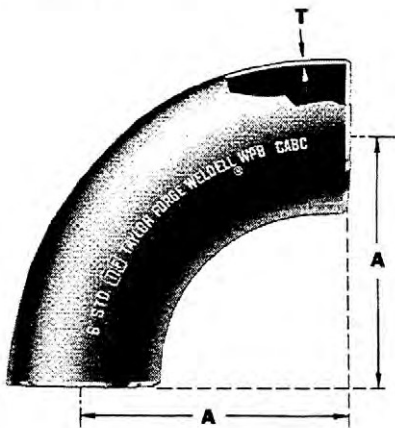

All dimensions are in inches.

Nominal Pipe Size	Nominal Wall Thickness	Center to Short End	Approx. Weight Pounds
	T	A	
2	.154	6	3.0
3	.216	9	9.2
4	.237	12	17.5
6	.280	18	48
8	.322	24	92
10	.365	30	164
12	.375	36	241
14	.375	42	309
16	.375	48	405



## TEES—Straight and Reducing

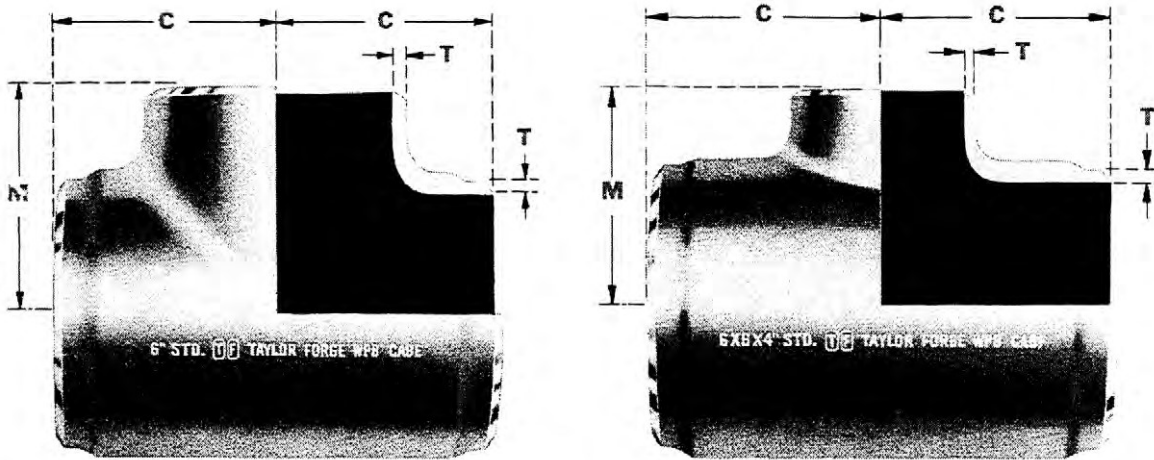

Nominal Pipe Size		Center to End		Approx Weight Pounds
Run	Branch	C	M	
½	½	1	1	.35
	¾	1	1	.25
	¼	1	1	.25
¾	¾	1½	1½	.45
	½	1½	1½	.50
	¾	1½	1½	.50
1	1	1½	1½	.63
	¾	1½	1½	.58
	½	1½	1½	.57
	¾	1½	1½	.56
1¼	1¼	1¾	1¾	1.16
	1	1¾	1¾	1.07
	¾	1¾	1¾	1.05
	½	1¾	1¾	1.03
1½	1½	2¼	2¼	1.70
	1¼	2¼	2¼	1.57
	1	2¼	2¼	1.55
	¾	2¼	2¼	1.52
	½	2¼	2¼	1.49

continued in next table

Nominal Pipe Size		Center to End		Approx Weight Pounds
Run	Branch	C	M	
2	2	2½	2½	4.16
	1½	2½	2¾	4.16
	1¼	2½	2¼	4.16
2½	1	2½	2	4.16
	¾	2½	1¾	4.16
	2½	3	3	5.91
2½	2	3	2¾	5.91
	1½	3	2¾	6.78
	1¼	3	2½	6.78
	1	3	2¼	6.78
3	3	3¾	3¾	8.41
	2½	3¾	3¼	8.41
	2	3¾	3	8.41
	1½	3¾	2¾	8.41
3	1¼	3¾	2¾	8.41
	1	3¾	2¾	8.41
	3½	3¾	3¾	11.4
	3	3¾	3¾	11.4
3½	2½	3¾	3½	11.4
	2	3¾	3¼	11.4
	1½	3¾	3¾	11.4

continued in next table

Nominal Pipe Size		Center to End		Approx Weight Pounds
Run	Branch	C	M	
4	4	4½	4½	13.2
	3½	4½	4	13.2
	3	4½	3¾	13.2
4	2½	4½	3¾	13.2
	2	4½	3½	13.2
	1½	4½	3¾	13.2
5	5	4¾	4¾	21.9
	4	4¾	4¾	21.9
	3½	4¾	4½	21.9
5	3	4¾	4¾	21.9
	2½	4¾	4¼	21.9
	2	4¾	4¾	21.9
6	6	5½	5½	36.3
	5	5½	5½	36.3
	4	5½	5½	32.9
6	3½	5½	5	32.9
	3	5½	4¾	32.9
	2½	5½	4¾	32.9
	2	5½	4¾	32.9

continued on next page



## TEES—Straight and Reducing continued from preceding page

Nominal Pipe Size		Center to End		Approx Weight Pounds
Run	Branch	of Run	of Branch	
8	8	7	7	61
	6	7	6 $\frac{5}{8}$	61
	5	7	6 $\frac{3}{8}$	61
	4	7	6 $\frac{1}{8}$	61
	3 $\frac{1}{2}$	7	6	61
	3	7	6	61
10	10	8 $\frac{1}{2}$	8 $\frac{1}{2}$	91
	8	8 $\frac{1}{2}$	8	88
	6	8 $\frac{1}{2}$	7 $\frac{5}{8}$	88
	5	8 $\frac{1}{2}$	7 $\frac{1}{2}$	88
	4	8 $\frac{1}{2}$	7 $\frac{1}{4}$	88
	3	8 $\frac{1}{2}$	7	88
12	12	10	10	147
	10	10	9 $\frac{1}{2}$	147
	8	10	9	143
	6	10	8 $\frac{3}{8}$	143
	5	10	8 $\frac{1}{2}$	143
	4	10	8 $\frac{1}{4}$	143
14	14	11	11	226
	12	11	10 $\frac{3}{4}$	226
	10	11	10 $\frac{1}{8}$	217
	8	11	9 $\frac{3}{4}$	217
	6	11	9 $\frac{1}{8}$	217
	16	16	12	12
14		12	12	242
12		12	11 $\frac{3}{8}$	242
10		12	11 $\frac{1}{8}$	235
8		12	10 $\frac{3}{4}$	235
6		12	10 $\frac{1}{8}$	235
18	18	13 $\frac{1}{2}$	13 $\frac{1}{2}$	333
	16	13 $\frac{1}{2}$	13	333
	14	13 $\frac{1}{2}$	13	333
	12	13 $\frac{1}{2}$	12 $\frac{3}{8}$	333
	10	13 $\frac{1}{2}$	12 $\frac{1}{8}$	319
	8	13 $\frac{1}{2}$	11 $\frac{3}{4}$	319
20	20	15	15	504
	18	15	14 $\frac{1}{2}$	504
	16	15	14	504
	14	15	14	493
	12	15	13 $\frac{3}{8}$	493
	10	15	13 $\frac{1}{8}$	482
8	15	12 $\frac{3}{4}$	482	

continued in next table

Nominal Pipe Size		Center to End		Approx Weight Pounds
Run	Branch	of Run	of Branch	
22	22	16 $\frac{1}{2}$	16 $\frac{1}{2}$	555
	20	16 $\frac{1}{2}$	16	555
	18	16 $\frac{1}{2}$	15 $\frac{1}{2}$	527
	16	16 $\frac{1}{2}$	15	527
	14	16 $\frac{1}{2}$	15	445
	12	16 $\frac{1}{2}$	14 $\frac{3}{8}$	445
10	16 $\frac{1}{2}$	14 $\frac{1}{8}$	445	
24†	24	17	17	765
	22	17	17	681
	20	17	17	601
	18	17	16 $\frac{1}{2}$	601
	16	17	16	506
	14	17	16	506
26†	26	19 $\frac{1}{2}$	19 $\frac{1}{2}$	826
	24	19 $\frac{1}{2}$	19	826
	22	19 $\frac{1}{2}$	18 $\frac{1}{2}$	727
	20	19 $\frac{1}{2}$	18	727
	18	19 $\frac{1}{2}$	17 $\frac{1}{2}$	614
	16	19 $\frac{1}{2}$	17	614
30†	30	22	22	1130
	26	22	21 $\frac{1}{2}$	1065
	24	22	21	1065
	22	22	20 $\frac{1}{2}$	921
	20	22	20	921
	18	22	19 $\frac{1}{2}$	921
36†	36	26 $\frac{1}{2}$	26 $\frac{1}{2}$	1617
	30	26 $\frac{1}{2}$	25	1524
	26	26 $\frac{1}{2}$	24 $\frac{1}{2}$	1321
	24	26 $\frac{1}{2}$	24	1321
	22	26 $\frac{1}{2}$	23 $\frac{1}{2}$	1321
	20	26 $\frac{1}{2}$	23	1321
18	18	26 $\frac{1}{2}$	22 $\frac{1}{2}$	1321
	16	26 $\frac{1}{2}$	22	1136

Nominal Pipe Size	DIMENSIONS COMMON TO FITTINGS AND PIPE		
	Outside Diameter	Inside Diameter	Wall Thickness
1/4	.540	.364	.088
	.675	.493	.091
	.840	.622	.109
3/4	1.050	.824	.113
	1.315	1.049	.133
	1.660	1.380	.140
1 1/2	1.900	1.610	.145
	2.375	2.067	.154
	2.875	2.469	.203
3	3.500	3.068	.216
	4.000	3.548	.226
	4.500	4.026	.237
5	5.563	5.047	.258
	6.625	6.065	.280
	8.625	7.981	.322
10	10.750	10.020	.365
	12.750	12.000	.375
	14.000	13.250	.375
16	16.000	15.250	.375
	18.000	17.250	.375
	20.000	19.250	.375
22	22.000	21.250	.375
	24.000	23.250	.375
	26.000	25.250	.375
30	30.000	29.250	.375
	36.000	35.250	.375

All dimensions are in inches.

## REDUCERS—Concentric and Eccentric

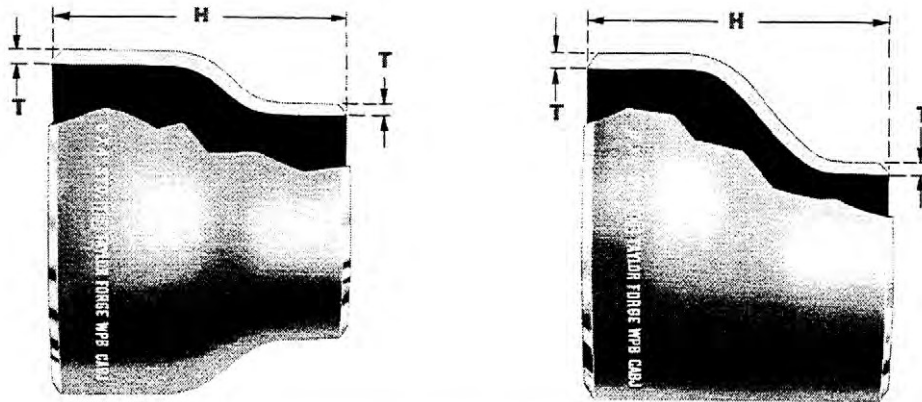

Nominal Pipe Size						Length H	Approx Weight Pounds
Large End	Small End Sizes						
3/4	1/2	3/8	--	--	--	1 1/2	.15
1	3/4	1/2	3/8	--	--	2	.28
1 1/4	1	3/4	1/2	--	--	2	.38
1 1/2	1 1/4	1	3/4	1/2	--	2 1/2	.57
2	1 1/2	1 1/4	1	3/4	--	3	.90
2 1/2	2	1 1/2	1 1/4	1	--	3 1/2	1.70
3	2 1/2	2	1 1/2	1 1/4	1	3 1/2	2.2
3 1/2	3	2 1/2	2	1 1/2	1 1/4	4	3.0
4	3 1/2	3	2 1/2	2	1 1/2	4	3.6
5	4	3 1/2	3	2 1/2	2	5	6.1
6	5	4	3 1/2	3	2 1/2	5 1/2	8.7
8	6	5	4	3 1/2	3	6	14.3
10	8	6	5	4	3	7	23.6
12	10	8	6	5	4	8	33.1
14	12	10	8	6	--	13	59.2
16	14	12	10	8	--	14	73
18	16	14	12	10	--	15	88
20	18	16	14	12	--	20	131
22	20	18	16	14	--	20	144
24	22	20	18	16	--	20	158
26	24	22	20	18	--	24	205
30	26	24	22	20	--	24	237
36	30	26	24	22	20	24	285
42	36	30	26	24	--	24	334

Nominal Pipe Size	DIMENSIONS COMMON TO FITTINGS AND PIPE		
	Outside Diameter	Inside Diameter	Wall Thick- ness
3/8	.675	.493	.091
1/2	.840	.622	.109
3/4	1.050	.824	.113
1	1.315	1.049	.133
1 1/4	1.660	1.380	.140
1 1/2	1.900	1.610	.145
2	2.375	2.067	.154
2 1/2	2.875	2.469	.203
3	3.500	3.068	.216
3 1/2	4.000	3.548	.226
4	4.500	4.026	.237
5	5.563	5.047	.258
6	6.625	6.065	.280
8	8.625	7.981	.322
10	10.750	10.020	.365
12	12.750	12.000	.375
14	14.000	13.250	.375
16	16.000	15.250	.375
18	18.000	17.250	.375
20	20.000	19.250	.375
22	22.000	21.250	.375
24	24.000	23.250	.375
26	26.000	25.250	.375
30	30.000	29.250	.375
36	36.000	35.250	.375
42	42.000	41.250	.375

All dimensions are in inches.



# STUB ENDS, CAPS, 180° RETURNS

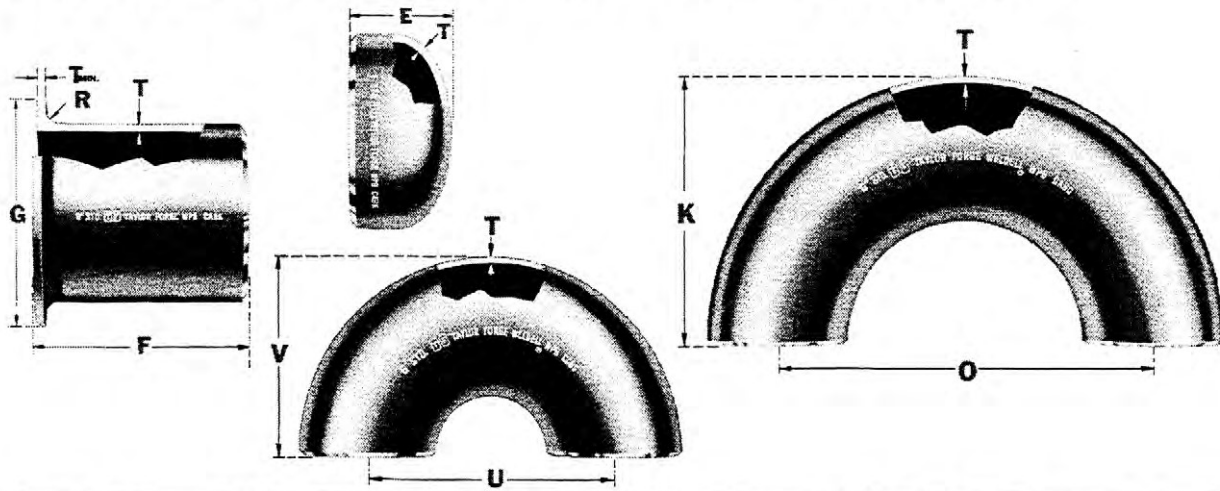

Nominal Pipe Size	Lap Joint Stub Ends				Caps	
	Length	Diameter of Lap	Radius	Approx Weight Pounds	Length	Approx Weight Pounds
	F	G	R		E	
1/2	3	1 3/8	1/8	.30	1	.07
3/4	3	1 11/16	1/8	.40	1 1/2	.13
1	4	2	1/8	.66	1 1/2	.22
1 1/4	4	2 1/2	3/16	.91	1 1/2	.31
1 1/2	4	2 3/8	1/4	1.22	1 1/2	.37
2	6	3 3/8	5/16	2.19	1 1/2	.51
2 1/2	6	4 1/8	5/16	3.45	1 1/2	.81
3	6	5	3/8	4.71	2	1.42
3 1/2	6	5 1/2	3/8	5.54	2 1/2	2.14
4	6	6 3/16	7/16	6.7	2 1/2	2.54
5	8	7 7/16	7/16	11.7	3	4.19
6	8	8 1/2	1/2	15.2	3 1/2	6.44
8	8	10 5/8	1/2	23	4	11.2
10	10	12 3/4	1/2	40	5	20.0
12	10	15	1/2	49	6	29.5
14	12	16 1/4	1/2	64	6 1/2	35.4
16	12	18 1/2	1/2	72	7	44.8
18	12	21	1/2	85	8	57.2
20	12	23	1/2	94	9	71
22	12	25 1/4	1/2	105	10	83
24	12	27 1/4	1/2	113	10 1/2	102
26	--	--	--	--	10 1/2	110
30	--	--	--	--	10 1/2	137
36	--	--	--	--	10 1/2	165

Nominal Pipe Size	180° Returns					
	LONG RADIUS			SHORT RADIUS		
	Center to Center	Back to Face	Approx Weight Pounds	Center to Center	Back to Face	Approx Weight Pounds
	O	K		U	V	
1/2	3	1 7/8	.35	--	--	--
3/4	2 1/4	1 11/16	.35	--	--	--
1	3	2 3/8	.69	2	1 5/8	.46
1 1/4	3 3/4	2 3/4	1.17	2 1/2	2 1/16	.78
1 1/2	4 1/2	3 1/4	1.68	3	2 7/16	1.12
2	6	4 3/8	3.00	4	3 3/16	2.00
2 1/2	7 1/2	5 5/16	5.96	5	3 13/16	3.96
3	9	6 1/4	9.36	6	4 3/4	6.24
3 1/2	10 1/2	7 1/4	13.10	7	5 1/2	8.76
4	12	8 1/4	17.8	8	6 1/4	11.9
5	15	10 3/16	30.2	10	7 3/4	20.2
6	18	12 3/16	47.0	12	9 5/16	31.2
8	24	16 3/16	94	16	12 3/16	63
10	30	20 3/8	167	20	15 3/8	111
12	36	24 3/8	246	24	18 3/8	164
14	42	28	316	28	21	210
16	48	32	414	32	24	276
18	54	36	526	36	27	350
20	60	40	646	40	30	430
22	66	44	784	--	--	--
24	72	48	936	48	36	626
26	78	52	1100	--	--	--
30	90	60	1466	60	45	976
36	--	--	--	72	54	1387

All dimensions are in inches.

# CROSSES—Straight and Reducing

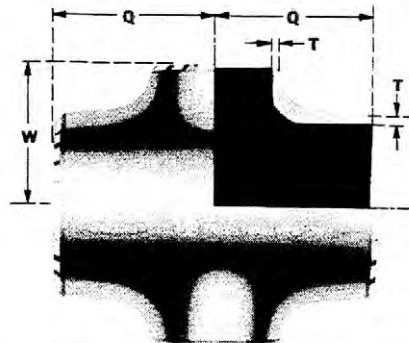
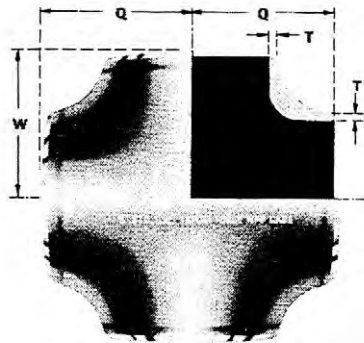

Nominal Pipe Size		Center to End		Approx Weight Pounds
Run	Branch	of Run	of Branch	
Run	Branch	Q	W	
1¼	1¼	1¾	1¾	1.53
	1	1¾	1¾	1.25
	¾	1¾	1¾	1.14
1½	1½	2¼	2¼	2.33
	1¼	2¼	2¼	1.92
	1	2¼	2¼	1.75
	¾	2¼	2¼	1.64
2	2	2½	2½	3.36
	1½	2½	2½	2.91
	1¼	2½	2½	2.68
	1	2½	2	2.52
2½	2½	3	3	5.87
	2	3	2¾	4.85
	1½	3	2¾	4.68
	1¼	3	2½	4.47
3	3	3¾	3¾	8.25
	2½	3¾	3¼	7.28
	2	3¾	3	6.71
3½	3½	4½	4½	13.9
	3	4½	4	12.4
	2½	4½	3¾	11.9
	2	4½	3¾	11.5
4	4	5½	5½	21.6
	3½	5½	5	18.8
	3	5½	4½	18.2
	2½	5½	4½	17.9
5	5	6½	6½	31.5
	4	6½	5½	27.7
	3½	6½	5½	26.6
	3	6½	5	26.3
6	6	7½	7½	57.1
	5	7½	6½	49.4
	4	7½	6½	48.4
	3½	7½	6	47.5
8	8	9½	9½	96
	6	9½	8	84
	5	9½	7½	82
	4	9½	7¼	81
10	10	11½	11½	168
	8	11½	10½	144
	6	11½	10½	138
	5	11½	10	117
12	12	13½	13½	278
	10	13½	13	236
	8	13½	12¾	228
	6	13½	12½	224
14	14	15½	15½	348
	12	15½	14½	298
	10	15½	14	290
	8	15½	14	284
16	16	17½	17½	488
	14	17½	16	426
	12	17½	15½	424
	10	17½	15½	422
18	18	19½	19½	688
	16	19½	18	626
	14	19½	17½	624
	12	19½	17½	622
20	20	21½	21½	928
	18	21½	20	866
	16	21½	20	864
	14	21½	20	862
24	24	25½	25½	1328
	20	25½	24	1266
	18	25½	24	1264
	16	25½	24	1262

continued in next table

Nominal Pipe Size		Center to End		Approx Weight Pounds
Run	Branch	of Run	of Branch	
Run	Branch	Q	W	
5	5	4¾	4¾	21.6
	4	4¾	4¾	18.8
	3½	4¾	4½	18.2
	3	4¾	4¾	17.9
6	6	5½	5½	31.5
	5	5½	5½	27.7
	4	5½	5½	26.6
	3½	5½	5	26.3
8	8	7	7	57.1
	6	7	6½	49.4
	5	7	6½	48.4
	4	7	6½	47.5
10	10	8½	8½	96
	8	8½	8	84
	6	8½	7½	82
	5	8½	7¼	81
12	12	10	10	139
	10	10	9½	123
	8	10	9	118
	6	10	8½	117
14	14	11	11	168
	12	11	10½	144
	10	11	10½	138
	8	11	9¾	136
16	16	13	13	216
	14	13	12½	188
	12	13	12½	182
	10	13	12½	176
18	18	15	15	278
	16	15	14½	236
	14	15	14	234
	12	15	14	228
20	20	17	17	348
	18	17	16½	298
	16	17	16½	290
	14	17	16½	284
24	24	19	19	488
	20	19	18	442
	18	19	18	436
	16	19	18	432

continued in next table

Nominal Pipe Size		Center to End		Approx Weight Pounds
Run	Branch	of Run	of Branch	
Run	Branch	Q	W	
16	16	12	12	216
	14	12	12	188
	12	12	11½	182
	10	12	11½	176
18	18	13½	13½	278
	16	13½	13	236
	14	13½	13	234
	12	13½	12¾	228
20	20	15	15	348
	18	15	14½	298
	16	15	14	290
	14	15	14	284
24	24	17	17	488
	20	17	17	442
	18	17	16½	436
	16	17	16	432

Bodies of crosses are thicker than ends to develop full pipe strength.



# 45° LATERALS—Straight and Reducing

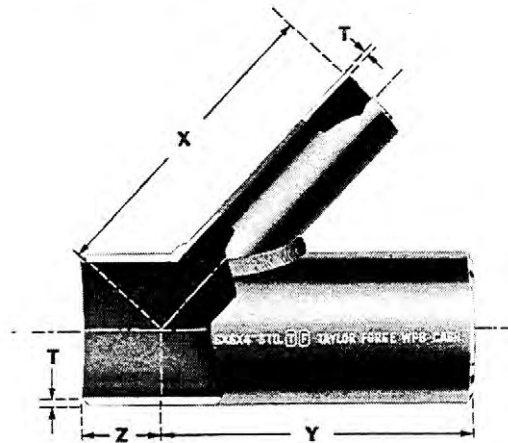
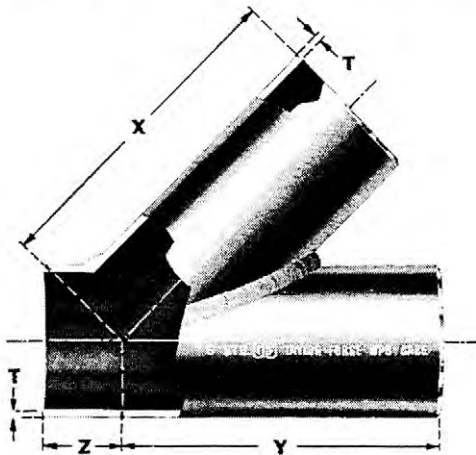

Nominal Pipe Size	Dimensions		Approx. Weight Pounds
	X and Y	Z	
1	3.5	1.75	1.7
1 1/4	4.25	2.0	2.4
1 1/2	5.0	2.5	3.3
2	6.0	3.25	5.0
2 1/2	7.0	3.5	9.0
3	7.75	3.75	12.5
3 1/2	8.375	4.0	17.2
4	8.5	4.5	20.5
5	11.0	4.75	31.0
6	12.5	5.25	42
8	15.25	6.25	76
10	18.0	7.0	124
12	21.5	8.0	180
14	25.0	10.0	218
16	28.5	12.0	275
18	32.0	13.0	326
20	35.0	14.0	396
24	41.25	16.25	544

Nominal Pipe Size	DIMENSIONS COMMON TO FITTINGS AND PIPE		
	Outside Diameter	Inside Diameter	Wall Thickness
3/4	1.050	.824	.113
1	1.315	1.049	.133
1 1/4	1.660	1.380	.140
1 1/2	1.900	1.610	.145
2	2.375	2.067	.154
2 1/2	2.875	2.469	.203
3	3.500	3.068	.216
3 1/2	4.000	3.548	.226
4	4.500	4.026	.237
5	5.563	5.047	.258
6	6.625	6.065	.280
8	8.625	7.981	.322
10	10.750	10.020	.365
12	12.750	12.000	.375
14	14.000	13.250	.375
16	16.000	15.250	.375
18	18.000	17.250	.375
20	20.000	19.250	.375
24	24.000	23.250	.375

All dimensions are in inches.

Laterals listed are fabricated from seamless Standard Wall Pipe. The pressure rating applicable to laterals is 40% of the allowable working pressure of the pipe from which the lateral is made. Where full allowable pipe pressure must be met, heavier laterals can be furnished with ends machined to match pipe dimensions.

# Extra Heavy Wall







## WeldELLS—90° and 45°

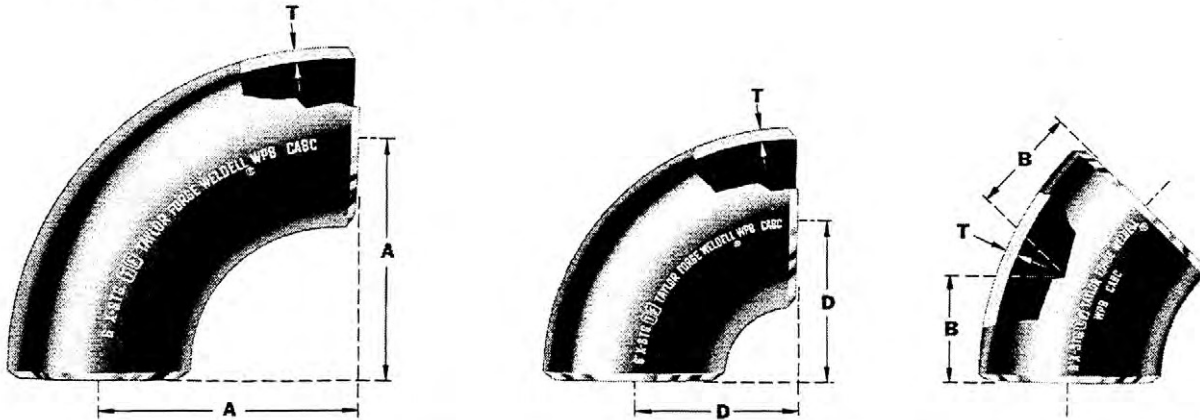

Nominal Pipe Size	90° WeldELLS				45° WeldELLS		DIMENSIONS COMMON TO FITTINGS AND PIPE			
	LONG RADIUS		SHORT RADIUS		Center to End	Approx Weight Pounds	Outside Diameter	Inside Diameter	Wall Thickness	
	Center to End	Approx Weight Pounds	Center to End	Approx Weight Pounds						B
	A		D							
1/2	1 1/2	.22	--	--	5/8	.11	1/2	.840	.546	.147
3/4	1 1/8	.23	--	--	9/16	.11	3/4	1.050	.742	.154
1	1 1/2	.45	--	--	7/8	.22	1	1.315	.957	.179
1 1/4	1 7/8	.77	--	--	1	.39	1 1/4	1.660	1.278	.191
1 1/2	2 1/4	1.12	1 1/2	.75	1 1/8	.56	1 1/2	1.900	1.500	.200
2	3	2.07	2	1.38	1 3/8	1.04	2	2.375	1.939	.218
2 1/2	3 3/4	3.95	2 1/2	2.64	1 3/4	1.98	2 1/2	2.875	2.323	.276
3	4 1/2	6.33	3	4.22	2	3.17	3	3.500	2.900	.300
3 1/2	5 1/4	9.04	3 1/2	6.04	2 1/4	4.52	3 1/2	4.000	3.364	.318
4	6	12.4	4	8.25	2 1/2	6.20	4	4.500	3.826	.337
5	7 1/2	21.4	5	14.30	3 1/8	10.70	5	5.563	4.813	.375
6	9	35.3	6	23.50	3 3/8	17.70	6	6.625	5.761	.432
8	12	71	8	47.7	5	35.8	8	8.625	7.625	.500
10	15	112	10	75.2	6 1/4	56.0	10	10.750	9.750	.500
12	18	162	12	108.0	7 1/2	81.0	12	12.750	11.750	.500
14	21	208	14	139	8 3/4	104	14	14.000	13.000	.500
16	24	273	16	182	10	137	16	16.000	15.000	.500
18	27	347	18	231	11 1/4	174	18	18.000	17.000	.500
20	30	428	20	286	12 1/2	214	20	20.000	19.000	.500
22	33	520	--	--	13 1/2	260	22	22.000	21.000	.500
24	36	622	24	415	15	311	24	24.000	23.000	.500
26	39	730	--	--	16	365	26	26.000	25.000	.500
30	45	972	30	649	18 1/2	486	30	30.000	29.000	.500
36	54	1407	36	939	22 1/4	704	36	36.000	35.000	.500
42	63	1916	48	1278	26	958	42	42.000	41.000	.500

All dimensions are in inches.



## WeldELLS 90° Reducing

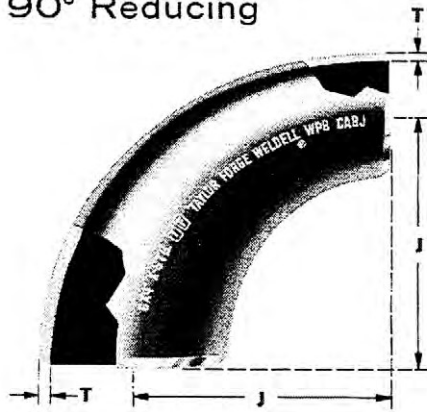

All dimensions are in inches.

Nominal Pipe Size	Center to End	Approx Weight Pounds
	J	
2 x 1½	3	2.00
2 x 1¼	3	1.75
2 x 1	3	1.50
2½ x 2	3¾	3.75
2½ x 1½	3¾	3.50
2½ x 1¼	3¾	3.25
3 x 2½	4½	6.00
3 x 2	4½	5.50
3 x 1½	4½	5.00
3½ x 3	5¼	8.25
3½ x 2½	5¼	7.75
3½ x 2	5¼	7.00
4 x 3½	6	11.50
4 x 3	6	10.75
4 x 2½	6	10.00
4 x 2	6	9.25

continued in next table

Nominal Pipe Size	Center to End	Approx Weight Pounds
	J	
5 x 4	7½	19.5
5 x 3½	7½	18.0
5 x 3	7½	16.5
5 x 2½	7½	15.5
6 x 5	9	32
6 x 4	9	30
6 x 3½	9	28
6 x 3	9	26
8 x 6	12	61
8 x 5	12	57
8 x 4	12	53
10 x 8	15	98
10 x 6	15	88
10 x 5	15	83
12 x 10	18	150
12 x 8	18	128
12 x 6	18	117

## WeldELLS 3R 90°

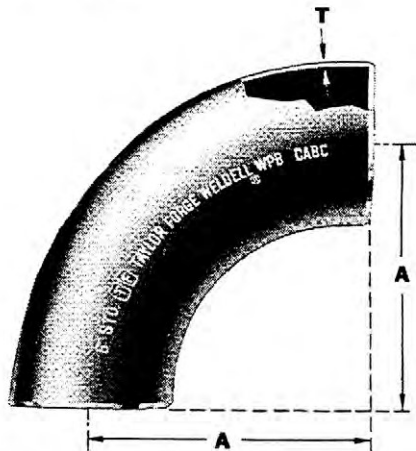

All dimensions are in inches.

Nominal Pipe Size	Nominal Wall Thickness T	Center to Short End A	Approx. Weight Pounds
2	.218	6	4.0
3	.300	9	12.4
4	.337	12	24.1
6	.432	18	64
8	.500	24	140
10	.500	30	221
12	.500	36	317
14	.500	42	407
16	.500	48	534

## TEES—Straight and Reducing

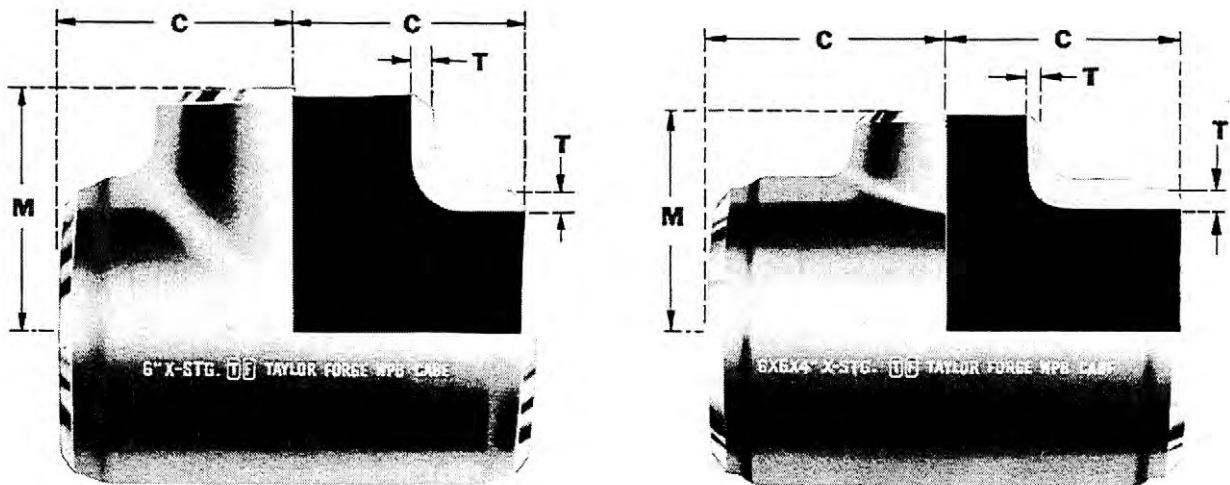

Nominal Pipe Size		Center to End		Approx Weight Pounds
Run	Branch	C	M	
1/2	1/2	1	1	.45
	3/8	1	1	.28
	1/4	1	1	.28
3/4	3/4	1 1/8	1 1/8	.60
	1/2	1 1/8	1 1/8	.50
	3/8	1 1/8	1 1/8	.50
1	1	1 1/2	1 1/2	.78
	3/4	1 1/2	1 1/2	.73
	1/2	1 1/2	1 1/2	.71
	3/8	1 1/2	1 1/2	.69
1 1/4	1 1/4	1 7/8	1 7/8	1.44
	1	1 7/8	1 7/8	1.33
	3/4	1 7/8	1 7/8	1.30
	1/2	1 7/8	1 7/8	1.27
1 1/2	1 1/2	2 1/4	2 1/4	2.12
	1 1/4	2 1/4	2 1/4	2.00
	1	2 1/4	2 1/4	1.93
	3/4	2 1/4	2 1/4	1.89
	1/2	2 1/4	2 1/4	1.86

*continued in next table*

Nominal Pipe Size		Center to End		Approx Weight Pounds
Run	Branch	C	M	
2	2	2 1/2	2 1/2	4.12
	1 1/2	2 1/2	2 3/8	4.12
	1 1/4	2 1/2	2 1/4	4.12
	1	2 1/2	2	4.12
	3/4	2 1/2	1 3/4	4.12
2 1/2	2 1/2	3	3	6.78
	2	3	2 3/4	6.78
	1 1/2	3	2 3/8	6.78
	1 1/4	3	2 1/2	6.78
	1	3	2 1/4	6.78
3	3	3 3/8	3 3/8	9.92
	2 1/2	3 3/8	3 3/4	9.92
	2	3 3/8	3	9.92
	1 1/2	3 3/8	2 7/8	9.92
	1 1/4	3 3/8	2 3/4	9.92
	1	3 3/8	2 3/8	9.92
3 1/2	3 1/2	3 3/4	3 3/4	13.6
	3	3 3/4	3 3/8	13.6
	2 1/2	3 3/4	3 1/2	13.6
	2	3 3/4	3 1/4	13.6
	1 1/2	3 3/4	3 3/8	13.6

*continued in next table*

Nominal Pipe Size		Center to End		Approx Weight Pounds
Run	Branch	C	M	
4	4	4 1/8	4 1/8	18.6
	3 1/2	4 1/8	4	18.6
	3	4 1/8	3 3/8	18.6
	2 1/2	4 1/8	3 3/4	18.6
	2	4 1/8	3 1/2	18.5
	1 1/2	4 1/8	3 3/8	18.5
5	5	4 7/8	4 7/8	28.5
	4	4 7/8	4 5/8	28.5
	3 1/2	4 7/8	4 1/2	28.5
	3	4 7/8	4 3/8	28.5
	2 1/2	4 7/8	4 1/4	28.5
	2	4 7/8	4 1/8	28.5
6	6	5 3/8	5 3/8	42.5
	5	5 3/8	5 3/8	42.5
	4	5 3/8	5 1/8	42.5
	3 1/2	5 3/8	5	42.5
	3	5 3/8	4 7/8	42.5
	2 1/2	5 3/8	4 3/4	42.5
	2	5 3/8	4 3/8	42.5

*continued on next page*



## TEES—Straight and Reducing continued from preceding page

Nominal Pipe Size		Center to End		Approx Weight Pounds
Run	Branch	of Run	of Branch	
8	8	7	7	76
	6	7	6 $\frac{3}{8}$	76
	5	7	6 $\frac{3}{8}$	76
	4	7	6 $\frac{1}{8}$	76
	3 $\frac{1}{2}$	7	6	76
	3	7	6	76
10	10	8 $\frac{1}{2}$	8 $\frac{1}{2}$	129
	8	8 $\frac{1}{2}$	8	116
	6	8 $\frac{1}{2}$	7 $\frac{3}{8}$	116
	5	8 $\frac{1}{2}$	7 $\frac{1}{2}$	116
	4	8 $\frac{1}{2}$	7 $\frac{1}{4}$	116
	3	8 $\frac{1}{2}$	7	102
12	12	10	10	187
	10	10	9 $\frac{1}{2}$	187
	8	10	9	180
	6	10	8 $\frac{3}{8}$	180
	5	10	8 $\frac{1}{2}$	180
	4	10	8 $\frac{1}{4}$	180
14	14	11	11	280
	12	11	10 $\frac{3}{8}$	280
	10	11	10 $\frac{1}{8}$	268
	8	11	9 $\frac{3}{4}$	268
	6	11	9 $\frac{3}{8}$	268
	6	11	9 $\frac{3}{8}$	268
16	16	12	12	369
	14	12	12	369
	12	12	11 $\frac{3}{8}$	359
	10	12	11 $\frac{1}{8}$	352
	8	12	10 $\frac{3}{4}$	352
	6	12	10 $\frac{3}{8}$	352
18	18	13 $\frac{1}{2}$	13 $\frac{1}{2}$	425
	16	13 $\frac{1}{2}$	13	425
	14	13 $\frac{1}{2}$	13	425
	12	13 $\frac{1}{2}$	12 $\frac{5}{8}$	339
	10	13 $\frac{1}{2}$	12 $\frac{1}{8}$	322
	8	13 $\frac{1}{2}$	11 $\frac{3}{4}$	322
20	20	15	15	583
	18	15	14 $\frac{1}{2}$	504
	16	15	14	504
	14	15	14	493
	12	15	13 $\frac{3}{8}$	493
	8	15	12 $\frac{3}{4}$	482

*continued in next table*

Nominal Pipe Size		Center to End		Approx Weight Pounds
Run	Branch	of Run	of Branch	
22	22	16 $\frac{1}{2}$	16 $\frac{1}{2}$	811
	20	16 $\frac{1}{2}$	16	811
	18	16 $\frac{1}{2}$	15 $\frac{1}{2}$	670
	16	16 $\frac{1}{2}$	15	670
	14	16 $\frac{1}{2}$	15	517
	10	16 $\frac{1}{2}$	14 $\frac{3}{8}$	517
24	24	17	17	934
	22	17	17	849
	20	17	17	683
	18	17	16 $\frac{1}{2}$	683
	16	17	16	509
	14	17	16	509
26	26	19 $\frac{1}{2}$	19 $\frac{1}{2}$	1121
	24	19 $\frac{1}{2}$	19	1121
	22	19 $\frac{1}{2}$	18 $\frac{1}{2}$	925
	20	19 $\frac{1}{2}$	18	925
	18	19 $\frac{1}{2}$	17 $\frac{1}{2}$	713
	16	19 $\frac{1}{2}$	17	713
30	30	22	22	1510
	26	22	21 $\frac{1}{2}$	1257
	24	22	21	1257
	22	22	20 $\frac{1}{2}$	1048
	20	22	20	1048
	18	22	19 $\frac{1}{2}$	1048
36	36	26 $\frac{1}{2}$	26 $\frac{1}{2}$	2165
	30	26 $\frac{1}{2}$	25	1893
	26	26 $\frac{1}{2}$	24 $\frac{1}{2}$	1504
	24	26 $\frac{1}{2}$	24	1504
	22	26 $\frac{1}{2}$	23 $\frac{1}{2}$	1504
	20	26 $\frac{1}{2}$	23	1504
36	18	26 $\frac{1}{2}$	22 $\frac{1}{2}$	1321
	16	26 $\frac{1}{2}$	22	1321

Nominal Pipe Size	DIMENSIONS COMMON TO FITTINGS AND PIPE		
	Outside Diameter	Inside Diameter	Wall Thickness
1/4	.540	.302	.119
	.675	.423	.126
	.840	.546	.147
3/4	1.050	.742	.154
	1.315	.957	.179
	1.660	1.278	.191
1 1/2	1.900	1.500	.200
	2.375	1.939	.218
	2.875	2.323	.276
2	3.500	2.900	.300
	4.000	3.364	.318
	4.500	3.826	.337
3	5.563	4.813	.375
	6.625	5.761	.432
	8.625	7.625	.500
10	10.750	9.750	.500
	12.750	11.750	.500
	14.000	13.000	.500
16	16.000	15.000	.500
	18.000	17.000	.500
	20.000	19.000	.500
22	22.000	21.000	.500
	24.000	23.000	.500
	26.000	25.000	.500
30	30.000	29.000	.500
	36.000	35.000	.500

All dimensions are in inches.

## REDUCERS—Concentric and Eccentric

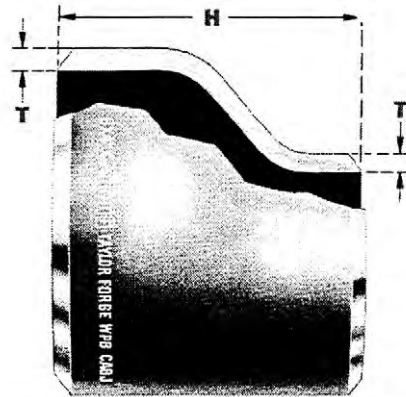
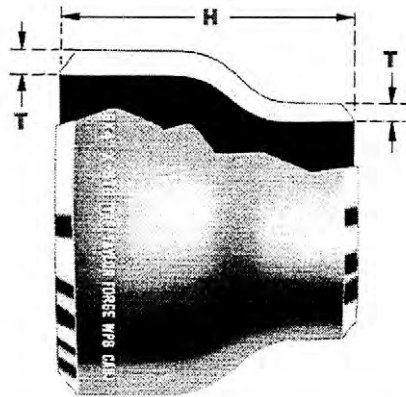

Nominal Pipe Size						Length H	Approx Weight Pounds
Large End	Small End Sizes						
3/4	1/2	3/8	--	--	--	1 1/2	.22
1	3/4	1/2	3/4	--	--	2	.36
1 1/4	1	3/4	1/2	--	--	2	.50
1 1/2	1 1/4	1	3/4	1/2	--	2 1/2	.76
2	1 1/2	1 1/4	1	3/4	--	3	1.25
2 1/2	2	1 1/2	1 1/4	1	--	3 1/2	2.23
3	2 1/2	2	1 1/2	1 1/4	1	3 1/2	2.99
3 1/2	3	2 1/2	2	1 1/2	1 1/4	4	4.16
4	3 1/2	3	2 1/2	2	1 1/2	4	5.00
5	4	3 1/2	3	2 1/2	2	5	8.65
6	5	4	3 1/2	3	2 1/2	5 1/2	13.10
8	6	5	4	3 1/2	3	6	21.72
10	8	6	5	4	3	7	31.9
12	10	8	6	5	4	8	43.6
14	12	10	8	6	--	13	78.3
16	14	12	10	8	--	14	97
18	16	14	12	10	--	15	117
20	18	16	14	12	--	20	174
22	20	18	16	14	--	20	191
24	22	20	18	16	--	20	210
26	24	22	20	18	--	24	272
30	26	24	22	20	--	24	315
36	30	26	24	22	--	24	379
42	36	30	26	24	--	24	443

Nominal Pipe Size	DIMENSIONS COMMON TO FITTINGS AND PIPE		
	Outside Diameter	Inside Diameter	Wall Thick- ness
3/8	.675	.423	.126
1/2	.840	.546	.147
3/4	1.050	.742	.154
1	1.315	.957	.179
1 1/4	1.660	1.278	.191
1 1/2	1.900	1.500	.200
2	2.375	1.939	.218
2 1/2	2.875	2.323	.276
3	3.500	2.900	.300
3 1/2	4.000	3.364	.318
4	4.500	3.826	.337
5	5.563	4.813	.375
6	6.625	5.761	.432
8	8.625	7.625	.500
10	10.750	9.750	.500
12	12.750	11.750	.500
14	14.000	13.000	.500
16	16.000	15.000	.500
18	18.000	17.000	.500
20	20.000	19.000	.500
22	22.000	21.000	.500
24	24.000	23.000	.500
26	26.000	25.000	.500
30	30.000	29.000	.500
36	36.000	35.000	.500
42	42.000	41.000	.500

All dimensions are in inches.



# STUB ENDS, CAPS, 180° RETURNS

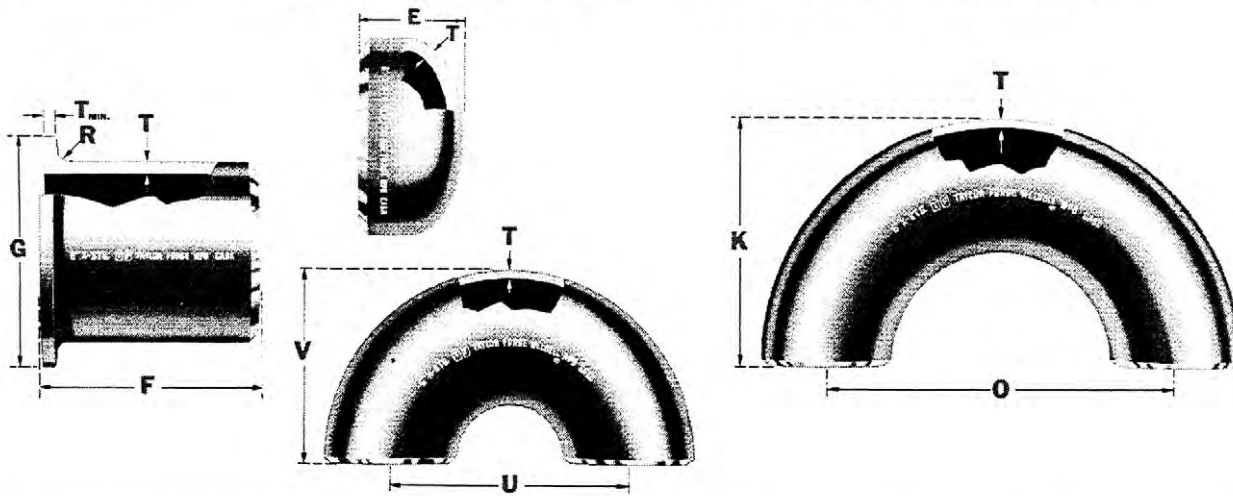

Nominal Pipe Size	Lap Joint Stub Ends				Caps	
	Length	Diameter of Lap	Radius	Approx Weight Pounds	Length	Approx Weight Pounds
	F	G	R		E	
1/2	3	1 3/8	1/8	.32	1	.10
3/4	3	1 11/16	1/8	.44	1 1/2	.19
1	4	2	1/8	.85	1 1/2	.28
1 1/4	4	2 1/2	3/16	1.21	1 1/2	.40
1 1/2	4	2 7/8	1/4	1.49	1 1/2	.49
2	6	3 3/8	3/16	3.01	1 1/2	.69
2 1/2	6	4 1/8	3/16	4.59	1 1/2	1.03
3	6	5	3/8	6.27	2	1.88
3 1/2	6	5 1/2	3/8	6.58	2 1/2	2.88
4	6	6 1/16	7/16	9.33	2 1/2	3.47
5	8	7 7/16	7/16	16.60	3	5.84
6	8	8 1/2	1/2	23.00	3 1/2	9.45
8	8	10 5/8	1/2	35.0	4	16.7
10	10	12 3/4	1/2	53.6	5	26.5
12	10	15	1/2	65.8	6	38.0
14	12	16 1/4	1/2	89	6 1/2	45.3
16	12	18 1/2	1/2	96	7	57.8
18	12	21	1/2	112	8	74.0
20	12	23	1/2	125	9	94
22	12	25 1/4	1/2	139	10	110
24	12	27 1/4	1/2	151	10 1/2	131
26	--	--	--	--	10 1/2	146
30	--	--	--	--	10 1/2	186
36	--	--	--	--	10 1/2	260

Nominal Pipe Size	180° Returns					
	LONG RADIUS			SHORT RADIUS		
	Center to Center	Back to Face	Approx Weight Pounds	Center to Center	Back to Face	Approx Weight Pounds
	O	K		U	V	
1/2	3	1 7/8	.45	--	--	--
3/4	2 1/4	1 11/16	.46	--	--	--
1	3	2 1/16	.89	--	--	--
1 1/4	3 3/4	2 3/4	1.54	--	--	--
1 1/2	4 1/2	3 1/4	2.24	3	2 7/16	1.50
2	6	4 3/16	4.14	4	3 3/16	2.76
2 1/2	7 1/2	5 5/16	7.90	5	3 11/16	5.28
3	9	6 1/4	12.70	6	4 3/4	8.44
3 1/2	10 1/2	7 1/4	18.10	7	5 1/2	12.10
4	12	8 1/4	24.8	8	6 1/4	16.5
5	15	10 9/16	42.8	10	7 3/4	28.6
6	18	12 3/16	70.6	12	9 1/16	47.0
8	24	16 3/16	143	16	12 3/16	95
10	30	20 3/8	224	20	15 3/8	150
12	36	24 3/8	324	24	18 3/8	216
14	42	28	416	28	21	278
16	48	32	546	32	24	364
18	54	36	694	36	27	462
20	60	40	856	40	30	572
22	66	44	1040	--	--	--
24	72	48	1244	48	36	830
26	78	52	1460	--	--	--
30	90	60	1944	60	45	1298
36	--	--	--	72	54	1838

All dimensions are in inches.

# CROSSES—Straight and Reducing

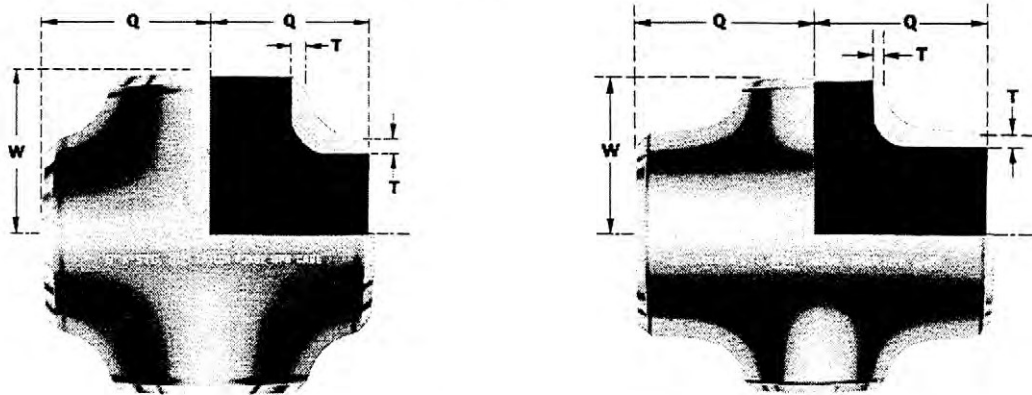

Nominal Pipe Size		Center to End		Approx Weight Pounds
Run	Branch	Q	W	
1/4	1 1/4	1 3/8	1 3/8	1.86
	1	1 1/8	1 1/8	1.53
	3/4	1 1/8	1 1/8	1.38
1/2	1 1/2	2 1/4	2 1/4	2.84
	1 1/4	2 1/4	2 1/4	2.36
	1	2 1/4	2 1/4	2.16
	3/4	2 1/4	2 1/4	2.03
2	2	2 1/2	2 1/2	4.18
	1 1/2	2 1/2	2 3/8	3.65
	1 1/4	2 1/2	2 1/4	3.37
	1	2 1/2	2	3.20
2 1/2	2 1/2	3	3	7.16
	2	3	2 3/4	5.99
	1 1/2	3	2 5/8	5.80
3	3	3 3/8	3 3/8	10.30
	2 1/2	3 3/8	3 1/4	8.91
	2	3 3/8	3	8.50
3 1/2	3 1/2	3 3/4	3 3/4	13.8
	3	3 3/4	3 3/8	12.2
	2 1/2	3 3/4	3 1/2	11.8
4	4	4 1/8	4 1/8	17.8
	3 1/2	4 1/8	4	15.9
4	3	4 1/8	3 3/8	15.4
	2 1/2	4 1/8	3 3/4	15.0
	2	4 1/8	3 1/2	14.4
	1 1/2	4 1/8	3 3/8	14.4

continued in next table

Nominal Pipe Size		Center to End		Approx Weight Pounds
Run	Branch	Q	W	
5	5	4 7/8	4 7/8	28.2
	4	4 7/8	4 5/8	24.8
	3 1/2	4 7/8	4 1/2	24.2
	3	4 7/8	4 3/8	23.8
6	6	5 5/8	5 5/8	43.4
	5	5 5/8	5 3/8	38.2
	4	5 5/8	5 1/8	37.1
	3 1/2	5 5/8	5	36.8
8	8	7	7	80
	6	7	6 5/8	70
	5	7	6 3/8	69
	4	7	6 1/8	68
10	10	8 1/2	8 1/2	123
	8	8 1/2	8	110
	6	8 1/2	7 5/8	106
	5	8 1/2	7 1/2	105
12	12	10	10	174
	10	10	9 1/2	155
	8	10	9	153
	6	10	8 5/8	150
14	14	11	11	214
	12	11	10 5/8	186
	10	11	10 1/8	178
	8	11	9 3/4	176

continued in next table

Nominal Pipe Size		Center to End		Approx Weight Pounds
Run	Branch	Q	W	
16	16	12	12	274
	14	12	12	240
	12	12	11 5/8	234
18	18	13 1/2	13 1/2	352
	16	13 1/2	13	300
	14	13 1/2	13	300
20	20	15	15	438
	18	15	14 1/2	380
	16	15	14	370
	14	15	14	364
24	24	17	17	610
	20	17	17	562
	18	17	16 1/2	558
	16	17	16	554

## 45° LATERALS—Straight and Reducing

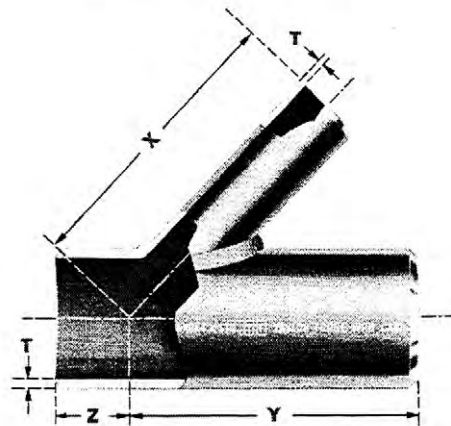
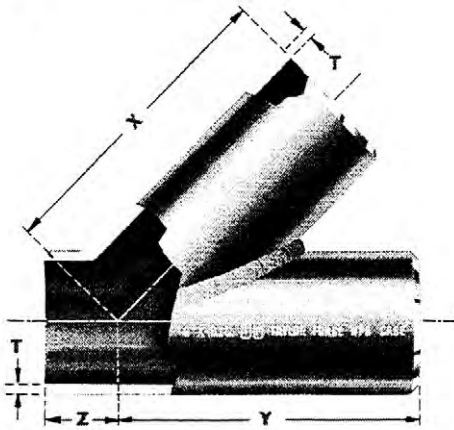

Nominal Pipe Size	Dimensions		Approx. Weight Pounds
	X and Y	Z	
<b>1</b>	3.5	1.75	2.5
<b>1¼</b>	4.25	2.0	3.8
<b>1½</b>	5.0	2.5	5.5
<b>2</b>	6.0	3.25	7.7
<b>2½</b>	7.0	3.5	13
<b>3</b>	7.75	3.75	18
<b>3½</b>	8.375	4.0	25
<b>4</b>	8.5	4.5	32
<b>5</b>	11.0	4.75	49
<b>6</b>	12.5	5.25	78
<b>8</b>	15.25	6.25	140
<b>10</b>	18.0	7.0	200
<b>12</b>	21.5	8.0	273
<b>14</b>	25.0	10.0	340
<b>16</b>	28.5	12.0	431
<b>18</b>	32.0	13.0	525
<b>20</b>	35.0	14.0	625
<b>24</b>	41.25	16.25	875

Nominal Pipe Size	DIMENSIONS COMMON TO FITTINGS AND PIPE		
	Outside Diameter	Inside Diameter	Wall Thickness
<b>¾</b>	1.050	.742	.154
<b>1</b>	1.315	.957	.179
<b>1¼</b>	1.660	1.278	.191
<b>1½</b>	1.900	1.500	.200
<b>2</b>	2.375	1.939	.218
<b>2½</b>	2.875	2.323	.276
<b>3</b>	3.500	2.900	.300
<b>3½</b>	4.000	3.364	.318
<b>4</b>	4.500	3.826	.337
<b>5</b>	5.563	4.813	.375
<b>6</b>	6.625	5.761	.432
<b>8</b>	8.625	7.625	.500
<b>10</b>	10.750	9.750	.500
<b>12</b>	12.750	11.750	.500
<b>14</b>	14.000	13.000	.500
<b>16</b>	16.000	15.000	.500
<b>18</b>	18.000	17.000	.500
<b>20</b>	20.000	19.000	.500
<b>24</b>	24.000	23.000	.500

All dimensions are in inches.



# Flanges





# AWWA C 207-94 Class D Steel Ring

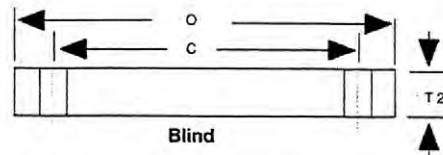
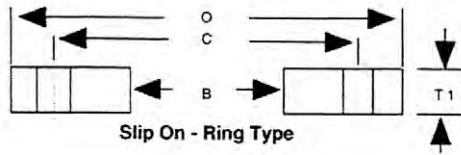

Nom Pipe Size	Outside Dia O	Bore B	Thickness		Drilling Template			Approx. Wt. (Lbs.)	
			Slip-On T1	Blind T2	No. Bolt Holes	Dia Holes	Bolt Circle C	Slip-On	Blind
4	9.00	4.57	0.625	0.625	8	0.750	7.50	7.9	11.0
5	10.00	5.66	0.625		8	0.875	8.50	10.1	
6	11.00	6.72	0.688	0.692	8	0.875	9.50	11.2	18.4
8	13.50	8.72	0.688	0.805	8	0.875	11.75	15.9	33.0
10	16.00	10.88	0.688	0.947	12	1.000	14.25	20.2	54.0
12	19.00	12.88	0.812	1.110	12	1.000	17.00	34.8	89.7
14	21.00	14.19	0.938	1.127	12	1.125	18.75	49.5	112.6
16	23.50	16.19	1.000	1.258	16	1.125	21.25	63.6	157.0
18	25.00	18.19	1.063	1.326	16	1.250	22.75	68.1	187.4
20	27.50	20.19	1.125	1.442	20	1.250	25.00	85.1	246.4
22	29.50	22.19	1.188		20	1.375	27.25	97.2	
24	32.00	24.25	1.250	1.657	20	1.375	29.50	120.1	385.8
30	38.75	30.25	1.375	2.003	28	1.375	36.00	177.2	684.7
36	46.00	36.25	1.625	2.369	32	1.625	42.75	286.4	1142.5
42	53.00	42.25	1.750	2.725	36	1.625	49.50	396.8	1751.3
48	59.50	48.25	1.875	3.067	44	1.625	56.00	468.8	2485.8
54	66.25	54.25	2.125	3.431	44	1.875	62.75	680.2	3452.5
60	73.00	60.25	2.250	3.774	52	1.875	69.25	845.7	4613.2
66	80.00	66.25	2.500	4.132	52	1.875	76.00	1122.4	6084.9
72	86.50	72.25	2.625	4.476	60	1.875	82.50	1323.8	7707.6
78	93.00	78.25	2.750		64	2.125	89.00	1541.7	
84	99.75	84.25	2.875		64	2.125	95.50	1751.7	
90	106.50	90.25	3.000		68	2.375	102.00	2135.5	
96	113.25	96.25	3.250		68	2.375	108.50	2391.4	
102	120.00	102.25	3.250		72	2.625	114.50	2861.5	
108	126.75	108.25	3.375		72	2.625	120.75	3167.8	
114	133.50	114.25	3.500		76	2.875	126.75	3714.0	
120	140.25	120.25	3.500		76	2.875	132.75	4093.8	
126	147.00	126.25	3.750		80	3.125	139.25	4730.9	
132	153.75	132.25	3.875		80	3.125	145.75	5182.7	
138	160.50	138.25	4.000		84	3.375	152.00	5916.0	
144	167.25	144.25	4.125		84	3.375	158.25	6447.3	

- 1) Furnished Flat Face Unless Otherwise Specified.
- 2) Other Bores and Facings Available Upon Request.
- 3) All Dimensions in inches.
- 4) Bores above 24" Are Not Specified by AWWA. Bores Shown are Commonly Used.
- 5) BLIND FLANGES: Above 48", designers should consider using dished heads welded to a standard flange.

**Class D Flanges:**

Service Rating at Atmospheric 4" to 12" - 175 psi  
 Temperature: 14" & larger - 150 psi

Drilling Template: To match ANSI B16.5 150# Standard.  
**AWWA WATER SERVICE RATING OF 150 psi**





SOCKET WELDING TYPE



REDUCING FLANGES

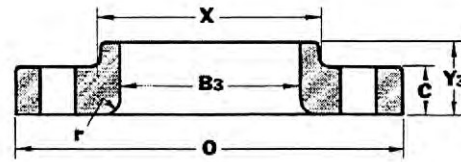

LAP JOINT



BLIND

Drilling Template and Bolting

Nominal Pipe Size	DRILLING			BOLTING			
	Bolt Circle Diam.	Number of Holes	Diam. of Holes	Diam. of Bolts	Machine Bolt Length	Stud Bolt Length +	
					Raised Face	Raised Face	Ring Joint
1/2	2 3/4	4	5/8	1/2	1 3/4	2 1/4	--
3/4	2 3/4	4	5/8	1/2	2	2 1/4	--
1	3 1/8	4	5/8	1/2	2	2 1/2	3
1 1/4	3 1/2	4	5/8	1/2	2 1/4	2 1/2	3
1 1/2	3 3/8	4	5/8	1/2	2 1/4	2 3/4	3 1/4
2	4 1/4	4	3/4	5/8	2 3/4	3	3 1/2
2 1/2	5 1/2	4	3/4	5/8	3	3 1/4	3 3/4
3	6	4	3/4	5/8	3	3 1/2	4
3 1/2	7	8	3/4	5/8	3	3 1/2	4
4	7 1/2	8	3/4	5/8	3	3 1/2	4
5	8 1/2	8	7/8	3/4	3 1/4	3 3/4	4 1/4
6	9 1/2	8	7/8	3/4	3 1/4	3 3/4	4 1/4
8	11 1/4	8	7/8	3/4	3 1/2	4	4 1/2
10	14 1/4	12	1	7/8	3 3/4	4 1/2	5
12	17	12	1	7/8	4	4 1/2	5
14	18 3/4	12	1 1/8	1	4 1/4	5	5 1/2
16	21 1/4	16	1 1/8	1	4 1/2	5 1/4	5 3/4
18	22 3/4	16	1 1/4	1 1/8	4 3/4	5 3/4	6 1/4
20	25	20	1 1/4	1 1/8	5 1/4	6	6 1/2
22†	27 1/4	20	1 3/8	1 1/4	5 1/2	6 1/2	7
24	29 1/2	20	1 3/8	1 1/4	5 3/4	6 3/4	7 1/4
26	31 3/4	24	1 3/8	1 1/4	6	7	--
28	34	28	1 3/8	1 1/4	6	7	--
30	36	28	1 3/8	1 1/4	6 1/4	7 1/4	--
32	38 1/2	28	1 3/8	1 1/2	6 3/4	8	--
34	40 1/2	32	1 5/8	1 1/2	7	8	--
36	42 3/4	32	1 5/8	1 1/2	7	8 1/4	--
42	49 1/2	36	1 5/8	1 1/2	7 1/2	8 3/4	--

All dimensions are in inches.

Weights

Nominal Pipe Size	APPROXIMATE WEIGHT EACH—POUNDS			
	Welding Neck	Slip-on and Thr'd	Lap Joint	Blind
1/2	2	1	1	1
3/4	2	2	2	2
1	3	2	2	2
1 1/4	3	3	3	3
1 1/2	4	3	3	4
2	6	5	5	5
2 1/2	8	7	7	7
3	10	8	8	9
3 1/2	12	11	11	13
4	15	13	13	17
5	19	15	15	20
6	24	19	19	26
8	39	30	30	45
10	52	43	43	70
12	80	64	64	110
14	110	90	105	140
16	140	98	140	180
18	150	130	160	220
20	180	165	195	285
22	225	185	245	355
24	260	220	275	430
26	300	250	--	525
28	315	285	--	620
30	360	315	--	720
32	435	395	--	870
34	465	420	--	990
36	520	480	--	1125
42	750	680	--	1625

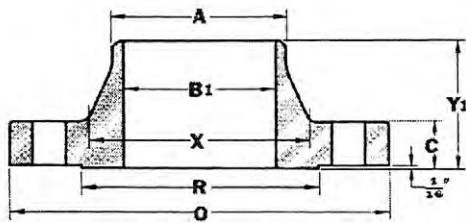

WELDING NECK

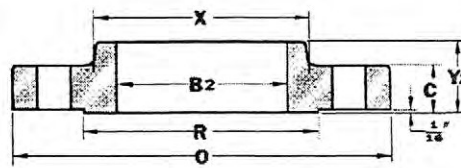

SLIP-ON

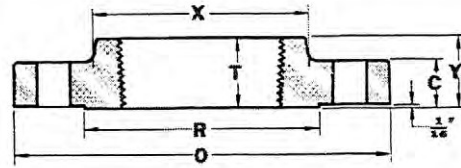

THREADED



Nominal Pipe Size	COMMON DIMENSIONS				BORE			LENGTH THRU HUB			Diam. Hub at Bevel	Radius of Fillet	Thread Length Min.
	Outside Diam.	Thick-ness Min. <sup>Δ</sup>	O. D. Raised Face	Diam. at Base of Hub	Weld-ing Neck	Slip-on	Lap Joint	Weld-ing Neck <sup>Δ</sup>	Slip-on and Thr'd <sup>Δ</sup>	Lap Joint			
	O	C	R	X	B1	B2	B3	Y1	Y2	Y3			
1/2	3 1/2	7/16	1 3/8	1 3/16	.62	.88	.90	1 7/8	5/8	5/8	.84	1/8	5/8
3/4	3 3/4	1/2	1 11/16	1 1/2	.82	1.09	1.11	2 1/16	3/4	3/4	1.05	1/8	3/4
1	4 1/4	5/8	2	1 15/16	1.05	1.36	1.38	2 3/16	1 1/16	1 1/16	1.32	1/8	1 1/16
1 1/4	4 5/8	3/4	2 1/2	2 5/16	1.38	1.70	1.72	2 1/4	1 3/16	1 3/16	1.66	3/16	1 3/16
1 1/2	5	1 1/16	2 7/8	2 3/8	1.61	1.95	1.97	2 7/16	7/8	7/8	1.90	1/4	7/8
2	6	3/4	3 3/8	3 1/16	2.07	2.44	2.46	2 1/2	1	1	2.38	3/16	1
2 1/2	7	7/8	4 1/8	3 3/8	2.47	2.94	2.97	2 3/4	1 1/8	1 1/8	2.88	3/16	1 1/8
3	7 1/2	1 1/16	5	4 1/4	3.07	3.57	3.60	2 3/4	1 3/16	1 3/16	3.50	3/16	1 3/16
3 1/2	8 1/2	1 1/16	5 1/2	4 1 1/16	3.55	4.07	4.10	2 1 1/16	1 1/4	1 1/4	4.00	3/16	1 1/4
4	9	1 5/16	6 3/16	5 5/16	4.03	4.57	4.60	3	1 3/16	1 3/16	4.50	7/16	1 3/16
5	10	1 1/16	7 3/16	6 7/16	5.05	5.66	5.69	3 1/2	1 7/16	1 7/16	5.56	7/16	1 7/16
6	11	1	8 1/2	7 7/16	6.07	6.72	6.75	3 1/2	1 7/16	1 7/16	6.63	7/16	1 7/16
8	13 1/2	1 1/8	10 5/8	9 1 1/16	7.98	8.72	8.75	4	1 3/4	1 3/4	8.63	1/2	1 3/4
10	16	1 3/16	12 3/4	12	10.02	10.88	10.92	4	1 1 1/16	1 1 1/16	10.75	1/2	1 1 1/16
12	19	1 1/4	15	14 3/8	12.00	12.88	12.92	4 1/2	2 3/16	2 3/16	12.75	1/2	2 3/16
14	21	1 3/8	16 1/4	15 3/4	13.25	14.14	14.18	5	2 1/4	3 3/8	14.00	1/2	2 1/4
16	23 1/2	1 7/16	18 1/2	18	15.25	16.16	16.19	5	2 1/2	3 3/16	16.00	1/2	2 1/2
18	25	1 7/16	21	19 3/8	17.25	18.18	18.20	5 1/2	2 1 1/16	3 1 1/16	18.00	1/2	2 1 1/16
20	27 1/2	1 1 1/16	23	22	19.25	20.20	20.25	5 1 1/16	2 7/8	4 1/16	20.00	1/2	2 7/8
22	29 1/2	1 1 3/16	25 1/4	24 1/4	21.25	22.22	22.25	5 7/8	3 1/8	4 1/4	22.00	1/2	3 1/8
24	32	1 3/8	27 1/4	26 3/4	23.25	24.25	24.25	6	3 1/4	4 3/8	24.00	1/2	3 1/4
26	34 1/4	2	29 1/4	28 1/2	As specified by purchaser	26.25	--	5	3 3/8	--	26.00	--	--
28	36 1/2	2 1/16	31 1/4	30 3/4		28.25	--	5 1/16	3 7/16	--	28.00	--	--
30	38 3/4	2 1/8	33 3/4	32 3/4		30.25	--	5 3/8	3 1/2	--	30.00	--	--
32	41 3/4	2 1/4	35 3/4	35		32.25	--	5 1/2	3 5/8	--	32.00	--	--
34	43 3/4	2 3/16	37 3/4	37		34.25	--	5 3/4	3 1 1/16	--	34.00	--	--
36	46	2 3/8	40 1/4	39 1/4		36.25	--	5 7/8	3 3/4	--	36.00	--	--
42	53	2 3/4	47	46		42.25	--	5 3/4	4	--	42.00	--	--

<sup>Δ</sup> The 1/16" raised face is included in Thickness C and Length Y.





SOCKET WELDING TYPE



REDUCING FLANGES

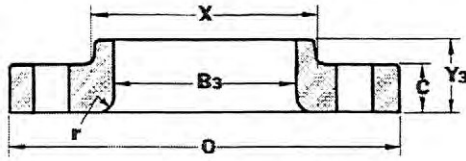

LAP JOINT

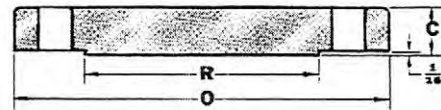

BLIND



Drilling Template and Bolting

Weights

Nominal Pipe Size	DRILLING			BOLTING			
	Bolt Circle Diam.	Number of Holes	Diam. of Holes	Diam. of Bolts	Machine Bolt Length	Stud Bolt Length +	
					Raised Face	Raised Face	Ring Joint
1/2	2 5/8	4	3/8	1/2	2	2 1/2	3
3/4	3 1/4	4	3/4	5/8	2 1/2	2 3/4	3 1/4
1	3 1/2	4	3/4	5/8	2 1/2	3	3 1/2
1 1/4	3 7/8	4	3/4	5/8	2 3/4	3	3 1/2
1 1/2	4 1/2	4	7/8	3/4	3	3 1/2	4
2	5	8	3/4	5/8	3	3 1/4	4
2 1/2	5 7/8	8	7/8	3/4	3 1/4	3 3/4	4 1/2
3	6 5/8	8	7/8	3/4	3 1/2	4	4 3/4
3 1/2	7 1/4	8	7/8	3/4	3 3/4	4 1/4	5
4	7 7/8	8	7/8	3/4	3 3/4	4 1/4	5
5	9 1/4	8	7/8	3/4	4	4 1/2	5 1/4
6	10 5/8	12	7/8	3/4	4 1/4	4 3/4	5 1/2
8	13	12	1	7/8	4 3/4	5 1/4	6
10	15 1/4	16	1 1/8	1	5 1/4	6	6 3/4
12	17 3/4	16	1 1/4	1 1/8	5 3/4	6 1/2	7 1/4
14	20 1/4	20	1 1/4	1 1/8	6	6 3/4	7 1/2
16	22 1/2	20	1 3/8	1 1/4	6 1/2	7 1/4	8
18	24 3/4	24	1 3/8	1 1/4	6 3/4	7 1/2	8 1/4
20	27	24	1 3/8	1 1/4	7	8	8 3/4
22†	29 1/4	24	1 5/8	1 1/2	7 1/2	8 3/4	9 3/4
24	32	24	1 5/8	1 1/2	7 3/4	9	10
26	34 1/2	28	1 3/4	1 5/8	8 3/4	10	11
28	37	28	1 3/4	1 5/8	9 1/4	10 1/2	11 1/2
30	39 1/4	28	1 7/8	1 3/4	10	11 1/4	12 1/4
32	41 1/2	28	2	1 7/8	10 1/2	12	13 1/4
34	43 1/2	28	2	1 7/8	10 3/4	12 1/4	13 1/2
36	46	32	2 1/8	2	11 1/4	12 3/4	14

Nominal Pipe Size	APPROXIMATE WEIGHT EACH—POUNDS			
	Welding Neck	Slip-on and Thr'd	Lap Joint	Blind
1/2	2	2	2	2
3/4	3	3	3	3
1	4	3	3	3
1 1/4	5	4	4	4
1 1/2	7	6	6	6
2	9	7	7	8
2 1/2	12	10	10	12
3	15	13	13	16
3 1/2	18	17	17	21
4	25	22	22	27
5	32	28	28	35
6	42	39	39	50
8	67	58	58	81
10	91	81	91	125
12	140	115	140	185
14	180	165	190	250
16	250	190	250	295
18	320	250	295	395
20	400	315	370	505
22	465	370	435	640
24	580	475	550	790
26	670	570	--	1050
28	810	720	--	1275
30	930	810	--	1500
32	1025	890	--	1775
34	1200	1075	--	2025
36	1300	1200	--	2275

All dimensions are in inches.

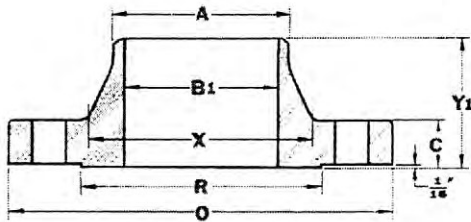

WELDING NECK

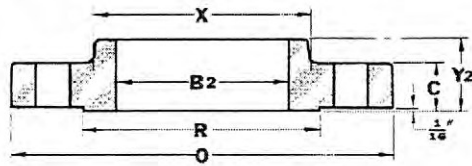

SLIP-ON

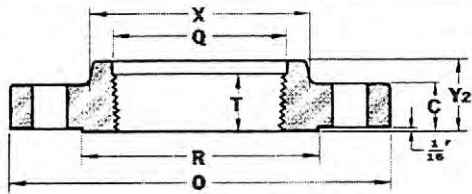

THREADED



Nominal Pipe Size	COMMON DIMENSIONS				BORE				LENGTH THRU HUB			Diam. Hub at Bevel	Radius of Fillet	Thread Length Min.
	Outside Diam.	Thickness Min. <sup>a</sup>	O.D. of Raised Face	Diam. at Base of Hub	Welding Neck	Slip-on	Lap Joint	Counter Bore Min.	Welding Neck <sup>a</sup>	Slip-on and Thr'd <sup>a</sup>	Lap Joint			
	O	C	R	X	B1	B2	B3	Q	Y1	Y2	Y3			
1/2	3 3/4	3/16	1 3/8	1 1/2	.62	.88	.90	.93	2 1/16	7/8	7/8	.84	1/8	5/8
3/4	4 1/2	3/8	1 11/16	1 7/8	.82	1.09	1.11	1.14	2 1/4	1	1	1.05	1/4	3/4
1	4 7/8	1/2	2	2 1/8	1.05	1.36	1.38	1.41	2 7/8	1 1/16	1 1/16	1.32	1/4	1 1/16
1 1/4	5 1/4	3/4	2 1/2	2 1/2	1.38	1.70	1.72	1.75	2 5/8	1 1/16	1 1/16	1.66	3/16	1 3/16
1 1/2	6 1/8	13/16	2 7/8	2 3/4	1.61	1.95	1.97	1.99	2 11/16	1 3/16	1 3/16	1.90	1/4	7/8
2	6 1/2	7/8	3 3/8	3 1/16	2.07	2.44	2.46	2.50	2 3/4	1 5/16	1 5/16	2.38	3/16	1 1/8
2 1/2	7 1/2	1	4 1/8	3 15/16	2.47	2.94	2.97	3.00	3	1 1/2	1 1/2	2.88	5/16	1 1/4
3	8 1/4	1 1/8	5	4 3/8	3.07	3.57	3.60	3.63	3 3/8	1 11/16	1 11/16	3.50	3/8	1 1/4
3 1/2	9	1 1/16	5 1/2	5 1/4	3.55	4.07	4.10	4.13	3 3/16	1 3/4	1 3/4	4.00	3/8	1 3/16
4	10	1 1/4	6 3/16	5 3/4	4.03	4.57	4.60	4.63	3 3/8	1 7/8	1 7/8	4.50	7/16	1 7/16
5	11	1 3/8	7 1/16	7	5.05	5.66	5.69	5.69	3 7/8	2	2	5.56	7/16	1 11/16
6	12 1/2	1 7/16	8 1/2	8 1/8	6.07	6.72	6.75	6.75	3 7/8	2 1/16	2 1/16	6.63	1/2	1 13/16
8	15	1 5/8	10 5/8	10 1/4	7.98	8.72	8.75	8.75	4 3/8	2 7/16	2 7/16	8.63	1/2	2
10	17 1/2	1 7/8	12 3/4	12 3/8	10.02	10.88	10.92	10.88	4 5/8	2 3/8	3 3/4	10.75	1/2	2 3/16
12	20 1/2	2	15	14 3/4	12.00	12.88	12.92	12.94	5 1/8	2 7/8	4	12.75	1/2	2 3/8
14	23	2 1/8	16 1/4	16 3/4	13.25	14.14	14.18	14.19	5 5/8	3	4 3/8	14.00	1/2	2 1/2
16	25 1/2	2 1/4	18 1/2	19	15.25	16.16	16.19	16.19	5 3/4	3 1/4	4 3/4	16.00	1/2	2 11/16
18	28	2 3/8	21	21	17.25	18.18	18.20	18.19	6 1/4	3 1/2	5 1/8	18.00	1/2	2 3/4
20	30 1/2	2 1/2	23	23 1/8	19.25	20.20	20.25	20.19	6 3/8	3 3/4	5 1/2	20.00	1/2	2 7/8
22	33	2 3/8	25 1/4	25 1/4	21.25	22.22	22.25	22.19	6 1/2	4	5 3/4	22.00	1/2	3 1/16
24	36	2 3/4	27 1/4	27 3/8	23.25	24.25	24.25	24.19	6 5/8	4 3/16	6	24.00	1/2	3 1/4
MSS—SP44 Class 300														
26	38 1/4	3 1/8	29 1/2	28 3/8	To be specified by purchaser	26.25	--	--	7 1/4	7 1/4	--	26 1/4	--	--
28	40 3/4	3 3/8	31 1/2	30 1/2	To be specified by purchaser	28.25	--	--	7 3/4	7 3/4	--	28 1/4	--	--
30	43	3 7/8	33 3/4	32 1/16	To be specified by purchaser	30.25	--	--	8 1/4	8 1/4	--	30 1/4	--	--
32	45 1/4	3 7/8	36	34 11/16	To be specified by purchaser	32.25	--	--	8 3/4	8 3/4	--	32 1/4	--	--
34	47 1/2	4	38	36 3/8	To be specified by purchaser	34.25	--	--	9 1/8	9 1/8	--	34 3/16	--	--
36	50	4 1/8	40 1/4	39	To be specified by purchaser	36.25	--	--	9 1/2	9 1/2	--	36 3/16	--	--

<sup>a</sup> The 1/16" raised face is included in Thickness C and Length Y.



SOCKET WELDING TYPE



REDUCING FLANGES

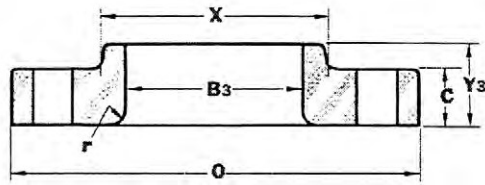

LAP JOINT

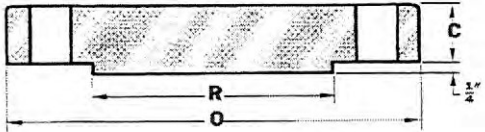

BLIND

Drilling Template and Bolting

Nominal Pipe Size	DRILLING			BOLTING			
	Bolt Circle Diam.	Number of Holes	Diam. of Holes	Diam. of Bolts	Stud Bolt Length +		
					1/4" Raised Face	Male-Female Tongue-Groove	Ring Joint
1/2	2 5/8	4	5/8	1/2	3	2 3/4	3
3/4	3 1/4	4	3/4	5/8	3 1/4	3	3 1/4
1	3 1/2	4	3/4	5/8	3 1/2	3 1/4	3 1/2
1 1/4	3 3/8	4	3/4	5/8	3 3/4	3 1/2	3 3/4
1 1/2	4 1/2	4	7/8	3/4	4	3 3/4	4
2	5	8	3/4	5/8	4	3 3/4	4 1/4
2 1/2	5 7/8	8	7/8	3/4	4 1/2	4 1/4	4 3/4
3	6 5/8	8	7/8	3/4	4 3/4	4 1/2	5
3 1/2	7 1/4	8	1	7/8	5 1/4	5	5 1/2
4	7 7/8	8	1	7/8	5 1/4	5	5 1/2
5	9 1/4	8	1	7/8	5 1/2	5 1/4	5 3/4
6	10 5/8	12	1	7/8	5 3/4	5 1/2	6
8	13	12	1 1/8	1	6 1/2	6 1/4	6 3/4
10	15 1/4	16	1 1/4	1 1/8	7 1/4	7	7 1/2
12	17 3/4	16	1 3/8	1 1/4	7 3/4	7 1/2	8
14	20 1/4	20	1 3/8	1 1/4	8	7 3/4	8 1/4
16	22 1/2	20	1 1/2	1 3/8	8 1/2	8 1/4	8 3/4
18	24 3/4	24	1 1/2	1 3/8	8 3/4	8 1/2	9
20	27	24	1 5/8	1 1/2	9 1/2	9 1/4	9 3/4
22	29 1/4	24	1 3/4	1 5/8	10	9 3/4	10 1/2
24	32	24	1 7/8	1 3/4	10 1/2	10 1/4	11
26	34 1/2	28	1 7/8	1 3/4	11 1/2	--	12
28	37	28	2	1 7/8	12 1/4	--	12 3/4
30	39 1/4	28	2 1/8	2	13	--	13 1/2
32	41 1/2	28	2 1/8	2	13 1/2	--	14 1/4
34	43 1/2	28	2 1/8	2	13 3/4	--	14 1/2
36	46	32	2 1/8	2	14	--	14 3/4

All dimensions are in inches.

Weights

Nominal Pipe Size	APPROXIMATE WEIGHT EACH—POUNDS			
	Welding Neck	Slip-on and Thr'd	Lap Joint	Blind
1/2	2	2	2	2
3/4	4	3	3	3
1	4	4	4	4
1 1/4	6	5	5	5
1 1/2	8	7	7	8
2	12	9	9	10
2 1/2	18	13	12	15
3	23	16	15	20
3 1/2	26	21	20	29
4	35	26	25	33
5	43	31	29	44
6	57	44	42	61
8	89	67	64	100
10	125	91	110	155
12	175	130	150	225
14	230	180	205	290
16	295	235	260	370
18	350	285	315	455
20	425	345	385	585
22	505	405	455	720
24	620	510	570	890
26	750	650	--	1125
28	880	780	--	1425
30	1000	900	--	1675
32	1150	1025	--	1975
34	1300	1150	--	2250
36	1475	1325	--	2525



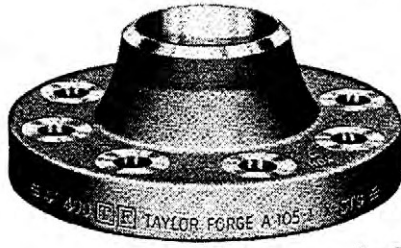
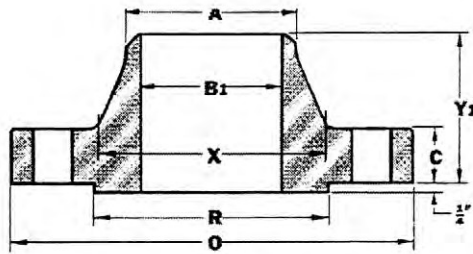

WELDING NECK

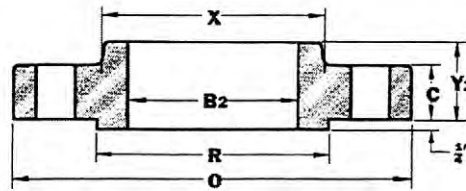

SLIP-ON

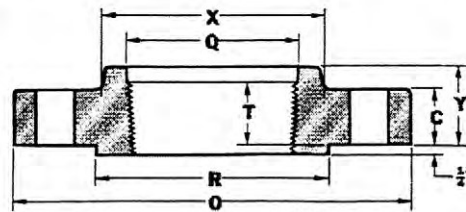

THREADED



Nominal Pipe Size	COMMON DIMENSIONS				BORE				LENGTH THRU HUB			Diam. Hub at Bevel	Radius of Fillet	Thread Length Min. <sup>Δ</sup>
	Outside Diam.	Thick-ness Min. <sup>Δ</sup>	O.D. of Raised Face	Diam. at Base of Hub	Welding Neck	Slip-on	Lap Joint	Counter Bore Min.	Welding Neck <sup>Δ</sup>	Slip-on and Thr'd <sup>Δ</sup>	Lap Joint			
1/2	3 3/4	3/16	1 3/8	1 1/2	To be specified by purchaser	.88	.90	.93	2 1/16	7/8	7/8	.84	1/8	3/8
3/4	4 5/8	5/16	1 11/16	1 7/8		1.09	1.11	1.14	2 1/4	1	1	1.05	1/8	5/8
1	4 7/8	1 1/16	2	2 1/8		1.36	1.38	1.41	2 7/8	1 1/8	1 1/8	1.32	1/8	1 1/16
1 1/4	5 1/4	1 3/16	2 1/2	2 1/2		1.70	1.72	1.75	2 3/8	1 1/2	1 1/8	1.66	3/16	1 3/16
1 1/2	6 1/8	3/8	2 3/8	2 3/4		1.95	1.97	1.99	2 3/4	1 1/4	1 1/4	1.90	1/4	3/8
2	6 1/2	1	3 3/8	3 3/16		2.44	2.46	2.50	2 7/8	1 7/8	1 7/8	2.38	3/16	1 1/8
2 1/2	7 1/2	1 1/8	4 1/8	3 11/16		2.94	2.97	3.00	3 3/8	1 5/8	1 5/8	2.88	3/8	1 1/4
3	8 1/4	1 1/4	5	4 3/8		3.57	3.60	3.63	3 1/4	1 13/16	1 13/16	3.50	3/8	1 3/8
3 1/2	9	1 3/8	5 1/2	5 1/4		4.07	4.10	4.13	3 3/8	1 13/16	1 13/16	4.00	3/8	1 1/2
4	10	1 3/8	6 3/16	5 3/4		4.57	4.60	4.63	3 1/2	2	2	4.50	7/16	1 7/16
5	11	1 1/2	7 3/16	7		5.66	5.69	5.69	4	2 1/8	2 1/8	5.56	7/16	1 11/16
6	12 1/2	1 5/8	8 1/2	8 1/8		6.72	6.75	6.75	4 1/16	2 1/4	2 1/4	6.63	1/2	1 13/16
8	15	1 7/8	10 5/8	10 1/4		8.72	8.75	8.75	4 5/8	2 11/16	2 11/16	8.63	1/2	2
10	17 1/2	2 1/8	12 3/4	12 5/8		10.88	10.92	10.88	4 7/8	2 7/8	4	10.75	1/2	2 3/16
12	20 1/2	2 1/4	15	14 3/4		12.88	12.92	12.94	5 3/8	3 1/8	4 1/4	12.75	1/2	2 3/8
14	23	2 3/8	16 1/4	16 3/4		14.14	14.18	14.19	5 7/8	3 3/8	4 5/8	14.00	1/2	2 1/2
16	25 1/2	2 1/2	18 1/2	19		16.16	16.19	16.19	6	3 11/16	5	16.00	1/2	2 11/16
18	28	2 5/8	21	21		18.18	18.20	18.19	6 1/2	3 3/8	5 3/8	18.00	1/2	2 3/4
20	30 1/2	2 3/4	23	23 1/8		20.20	20.25	20.19	6 5/8	4	5 3/4	20.00	1/2	2 7/8
22	33	2 7/8	25 1/4	25 1/4		22.22	22.25	22.19	6 3/4	4 1/4	6	22.00	1/2	3 1/16
24	36	3	27 1/4	27 5/8		24.25	24.25	24.19	6 7/8	4 1/2	6 1/4	24.00	1/2	3 1/4
26	38 1/4	3 1/2	29 1/2	28 5/8		26.25	--	--	7 3/8	7 3/8	--	26 5/16	--	--
28	40 3/4	3 3/4	31 1/2	30 13/16		28.25	--	--	8 1/8	8 1/8	--	28 3/8	--	--
30	43	4	33 3/4	32 13/16		30.25	--	--	8 3/8	8 3/8	--	30 3/8	--	--
32	45 1/4	4 1/4	36	35	32.25	--	--	9 1/8	9 1/8	--	32 3/8	--	--	
34	47 1/2	4 3/8	38	37 3/16	34.25	--	--	9 1/2	9 1/2	--	34 3/8	--	--	
36	50	4 1/2	40 1/4	39 3/8	36.25	--	--	9 7/8	9 7/8	--	36 7/8	--	--	

<sup>Δ</sup> The 1/4" raised face is not included in Thickness C, Length Y or Thread Length T.





SOCKET WELDING TYPE

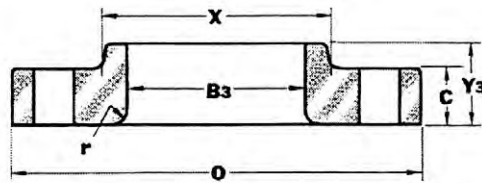

LAP JOINT



REDUCING FLANGES



BLIND



Drilling Template and Bolting

Nominal Pipe Size	DRILLING			BOLTING			
	Bolt Circle Diam.	Number of Holes	Diam. of Holes	Diam. of Bolts	Stud Bolt Length +		
					1/4" Raised Face	Male-Female Tongue-Groove	Ring Joint
1/2	2 5/8	4	5/8	1/2	3	2 3/4	3
3/4	3 1/4	4	3/4	5/8	3 1/4	3	3 1/4
1	3 1/2	4	3/4	5/8	3 1/2	3 1/4	3 1/2
1 1/4	3 7/8	4	3/4	5/8	3 3/4	3 1/2	3 3/4
1 1/2	4 1/2	4	7/8	3/4	4	3 3/4	4
2	5	8	3/4	5/8	4	3 3/4	4 1/4
2 1/2	5 7/8	8	7/8	3/4	4 1/2	4 1/4	4 3/4
3	6 5/8	8	7/8	3/4	4 3/4	4 1/2	5
3 1/2	7 1/4	8	1	7/8	5 1/4	5	5 1/2
4	8 1/2	8	1	7/8	5 1/2	5 1/4	5 3/4
5	10 1/2	8	1 1/8	1	6 1/4	6	6 1/2
6	11 1/2	12	1 1/8	1	6 1/2	6 1/4	6 3/4
8	13 3/4	12	1 1/4	1 1/8	7 1/2	7 1/4	7 3/4
10	17	16	1 3/8	1 1/4	8 1/4	8	8 1/2
12	19 1/4	20	1 3/8	1 1/4	8 1/2	8 1/4	8 3/4
14	20 3/4	20	1 1/2	1 3/8	9	8 3/4	9 1/4
16	23 3/4	20	1 5/8	1 1/2	9 3/4	9 1/2	10
18	25 3/4	20	1 3/4	1 5/8	10 1/2	10 1/4	10 3/4
20	28 1/2	24	1 3/4	1 5/8	11 1/4	11	11 1/2
22	30 5/8	24	1 7/8	1 3/4	12	11 3/4	12 1/2
24	33	24	2	1 7/8	12 3/4	12 1/2	13 1/4
26	36	28	2	1 7/8	13 1/4	--	13 3/4
28	38	28	2 1/8	2	13 3/4	--	14 1/4
30	40 1/4	28	2 1/8	2	14	--	14 1/2
32	42 1/2	28	2 3/8	2 1/4	14 3/4	--	15 1/2
34	44 1/2	28	2 3/8	2 1/4	15	--	15 3/4
36	47	28	2 3/8	2 1/2	15 3/4	--	16 1/2

All dimensions are in inches.

Weights

Nominal Pipe Size	APPROXIMATE WEIGHT EACH—POUNDS			
	Welding Neck	Slip-on and Thr'd	Lap Joint	Blind
1/2	2	2	2	2
3/4	4	3	3	3
1	4	4	4	4
1 1/4	6	5	5	5
1 1/2	8	7	7	8
2	12	9	9	10
2 1/2	18	13	12	15
3	23	16	15	20
3 1/2	26	21	20	29
4	42	37	36	41
5	68	63	61	68
6	81	80	78	86
8	120	115	110	140
10	190	170	170	230
12	225	200	200	295
14	280	230	250	355
16	390	330	365	495
18	475	400	435	630
20	590	510	570	810
22	720	590	670	1000
24	830	730	810	1250
26	1025	950	--	1525
28	1175	1075	--	1750
30	1300	1175	--	2000
32	1500	1375	--	2300
34	1650	1500	--	2575
36	1750	1600	--	2950

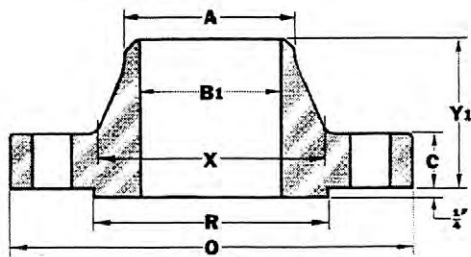

WELDING NECK

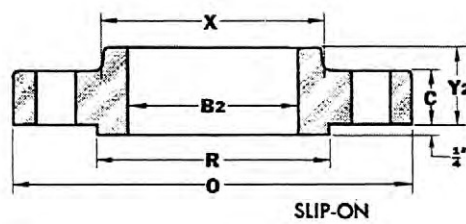

SLIP-ON

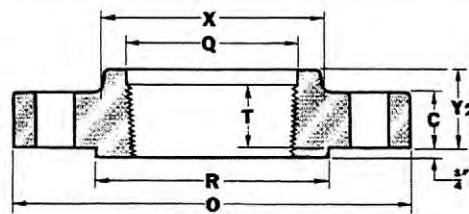

THREADED



Nominal Pipe Size	COMMON DIMENSIONS				Welding Neck	BORE			LENGTH THRU HUB			Diam. Hub at Bevel	Radius of Fillet	Thread Length Min. <sup>Δ</sup>	
	Outside Diam.	Thickness Min. <sup>Δ</sup>	O.D. of Raised Face	Diam. at Base of Hub		Slip-on	Lap Joint	Counter Bore Min.	Welding Neck <sup>Δ</sup>	Slip-on and Thr'd <sup>Δ</sup>	Lap Joint				
	O	C	R	X		B1	B2	B3	Q	Y1	Y2				Y3
1/2	3 3/4	5/16	1 3/8	1 1/2	To be specified by purchaser	.88	.90	.93	2 1/8	7/8	3/8	.84	1/8	5/8	
3/4	4 5/8	5/8	1 11/16	1 3/4		1.09	1.11	1.14	2 1/4	1	1	1.05	1/8	5/8	
1	4 7/8	1 1/16	2	2 1/4		1.36	1.38	1.41	2 7/8	1 1/8	1 1/8	1.32	1/8	1 1/8	
1 1/4	5 1/4	1 3/16	2 1/2	2 1/2		1.70	1.72	1.75	2 5/8	1 1/8	1 1/8	1.66	3/16	1 3/16	
1 1/2	6 1/8	3/8	2 7/8	2 3/4		1.95	1.97	1.99	2 3/4	1 1/4	1 1/4	1.90	1/4	7/8	
2	6 1/2	1	3 3/8	3 3/16		2.44	2.46	2.50	2 7/8	1 7/8	1 7/8	2.38	3/16	1 1/8	
2 1/2	7 1/2	1 1/8	4 1/8	3 15/16		2.94	2.97	3.00	3 1/8	1 5/8	1 5/8	2.88	5/16	1 1/4	
3	8 1/4	1 1/4	5	4 3/8		3.57	3.60	3.63	3 3/4	1 11/16	1 11/16	3.50	3/8	1 3/8	
3 1/2	9	1 3/8	5 1/2	5 1/4		4.07	4.10	4.13	3 3/8	1 15/16	1 15/16	4.00	3/8	1 3/8	
4	10 3/4	1 1/2	6 3/16	6		4.57	4.60	4.63	4	2 1/8	2 1/8	4.50	3/8	1 5/8	
5	13	1 3/4	7 7/16	7 7/16		5.66	5.69	5.69	4 1/2	2 3/8	2 3/8	5.56	7/16	1 7/8	
6	14	1 7/8	8 1/2	8 3/4		6.72	6.75	6.75	4 5/8	2 3/8	2 3/8	6.63	1/2	2	
8	16 1/2	2 3/16	10 5/8	10 3/4		8.72	8.75	8.75	5 1/4	3	3	8.63	1/2	2 1/4	
10	20	2 1/2	12 3/4	13 1/2		10.88	10.92	10.88	6	3 3/8	4 3/8	10.75	1/2	2 3/8	
12	22	2 5/8	15	15 3/4		12.88	12.92	12.94	6 1/8	3 3/8	4 3/8	12.75	1/2	2 3/4	
14	23 3/4	2 3/4	16 1/4	17		14.14	14.18	14.19	6 1/2	3 11/16	5	14.00	1/2	2 7/8	
16	27	3	18 1/2	19 1/2		16.16	16.19	16.19	7	4 3/16	5 1/2	16.00	1/2	3 1/16	
18	29 1/4	3 1/4	21	21 1/2		18.18	18.20	18.19	7 1/4	4 3/8	6	18.00	1/2	3 3/8	
20	32	3 1/2	23	24		20.20	20.25	20.19	7 1/2	5	6 1/2	20.00	1/2	3 1/4	
22	34 1/4	3 3/4	25 1/4	26 1/4		22.22	22.25	22.19	7 3/4	5 1/4	6 7/8	22.00	1/2	3 7/16	
24	37	4	27 1/4	28 1/4		24.25	24.25	24.19	8	5 1/2	7 1/4	24.00	1/2	3 5/8	
MSS—SP44 Class 600															
26	40	4 1/4	29 1/2	29 7/16		To be specified by purchaser	26.25	--	--	8 3/4	8 3/4	--	26 7/16	--	--
28	42 1/4	4 3/8	31 1/2	31 3/8			28.25	--	--	9 1/4	9 1/4	--	28 1/2	--	--
30	44 1/2	4 1/2	33 3/4	33 15/16	30.25		--	--	9 3/4	9 3/4	--	30 1/2	--	--	
32	47	4 3/8	36	36 1/8	To be specified by purchaser	32.25	--	--	10 1/4	10 1/4	--	32 1/2	--	--	
34	49	4 3/4	38	38 3/16		34.25	--	--	10 3/8	10 3/8	--	34 3/16	--	--	
36	51 3/4	4 7/8	40 1/4	40 5/8		36.25	--	--	11 1/8	11 1/8	--	36 1/8	--	--	

<sup>Δ</sup> The 1/4" raised face is not included in Thickness C, Length Y or Thread Length T.



SOCKET WELDING TYPE



REDUCING FLANGES

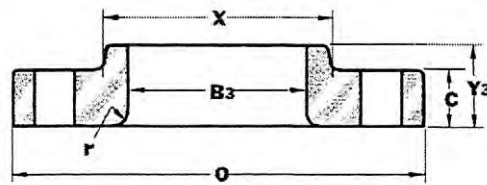

LAP JOINT

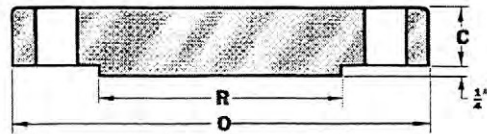

BLIND

Drilling Template and Bolting

Nominal Pipe Size	DRILLING			BOLTING			
	Bolt Circle Diam.	Number of Holes	Diam. of Holes	Diam. of Bolts	Stud Bolt Length +		
					1/4" Raised Face	Male-Female Tongue-Groove	Ring Joint
1/2	3 1/4	4	3/8	3/4	4	3 3/4	4
3/4	3 1/2	4	7/8	3/4	4 1/4	4	4 1/4
1	4	4	1	7/8	4 3/4	4 1/2	4 3/4
1 1/4	4 3/8	4	1	7/8	4 3/4	4 1/2	4 3/4
1 1/2	4 3/8	4	1 1/8	1	5 1/4	5	5 1/4
2	6 1/2	8	1	7/8	5 1/2	5 1/4	5 3/4
2 1/2	7 1/2	8	1 1/8	1	6	5 3/4	6 1/4
3	7 1/2	8	1	7/8	5 1/2	5 1/4	5 3/4
4	9 1/4	8	1 1/4	1 1/8	6 1/2	6 1/4	6 3/4
5	11	8	1 3/8	1 1/4	7 1/4	7	7 1/2
6	12 1/2	12	1 1/4	1 1/8	7 1/2	7 1/4	7 1/2
8	15 1/2	12	1 1/2	1 3/8	8 1/2	8 1/4	8 3/4
10	18 1/2	16	1 1/2	1 3/8	9	8 3/4	9 1/4
12	21	20	1 1/2	1 3/8	9 3/4	9 1/2	10
14	22	20	1 3/8	1 1/2	10 1/2	10 1/4	11
16	24 1/4	20	1 3/4	1 3/8	11	10 3/4	11 1/2
18	27	20	2	1 7/8	12 3/4	12 1/2	13 1/4
20	29 1/2	20	2 1/8	2	13 1/2	13 1/4	14
24	35 1/2	20	2 5/8	2 1/2	17	16 3/4	17 3/4
26	37 1/2	20	2 7/8	2 3/4	17 1/2	--	18 3/4
28	40 1/4	20	3 1/8	3	18 1/4	--	19 1/2
30	42 3/4	20	3 3/8	3	18 3/4	--	20
32	45 1/2	20	3 3/4	3 1/4	20	--	21 1/4
34	48 1/4	20	3 5/8	3 1/2	21	--	22 1/2
36	50 3/4	20	3 5/8	3 1/2	21 1/2	--	23

All dimensions are in inches.

Weights

Nominal Pipe Size	APPROXIMATE WEIGHT EACH—POUNDS			
	Welding Neck	Slip-on and Thr'd	Lap Joint	Blind
1/2	5	4	4	4
3/4	6	5	5	6
1	9	8	8	8
1 1/4	10	9	9	9
1 1/2	13	12	12	13
2	25	25	25	25
2 1/2	36	36	35	35
3	31	26	25	29
4	51	53	51	54
5	86	83	81	87
6	110	110	105	115
8	175	170	190	200
10	260	245	275	290
12	325	325	370	415
14	400	400	415	520
16	495	425	465	600
18	680	600	650	850
20	830	730	810	1075
24	1500	1400	1550	2025
26	1575	1525	--	2200
28	1850	1800	--	2575
30	2150	2075	--	3025
32	2575	2500	--	3650
34	3025	2950	--	4275
36	3450	3350	--	4900

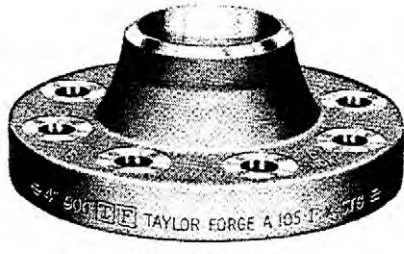
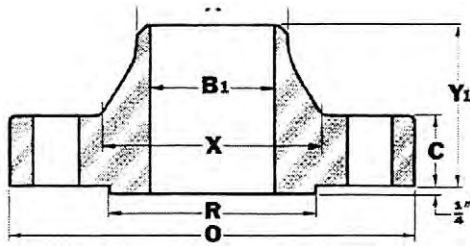

WELDING NECK

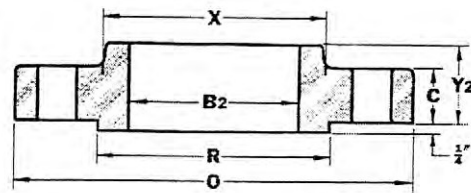

SLIP-ON

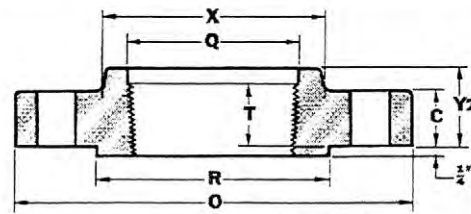

THREADED



Nominal Pipe Size	COMMON DIMENSIONS				BORE				LENGTH THRU HUB			Diam. Hub at Bevel	Radius of Fillet	Thread Length Min. <sup>Δ</sup>	
	Outside Diam.	Thick-ness Min. <sup>Δ</sup>	O.D. of Raised Face	Diam. at Base of Hub	Weld- ing Neck	Slip- on	Lap Joint	Counter Bore Min.	Weld- ing Neck <sup>Δ</sup>	Slip-on and Thr'd <sup>Δ</sup>	Lap Joint				
	O	C	R	X	B1	B2	B3	Q	Y1	Y2	Y3				A
1/2	4 3/4	7/8	1 1/4	1 1/2	To be specified by purchaser	.88	.90	.93	2 3/8	1 1/4	1 1/4	.84	1/8	7/8	
3/4	5 1/4	1	1 1/4	1 3/4		1.09	1.11	1.14	2 3/4	1 3/4	1 3/4	1.05	1/8	1	
1	5 3/4	1 1/8	2	2 1/4		1.36	1.38	1.41	2 3/4	1 3/4	1 3/4	1.32	1/8	1 1/8	
1 1/4	6 1/4	1 1/8	2 1/2	2 1/2		1.70	1.72	1.75	2 3/8	1 5/8	1 5/8	1.66	3/16	1 3/8	
1 1/2	7	1 1/4	2 3/4	2 3/4		1.95	1.97	1.99	3 1/4	1 3/4	1 3/4	1.90	1/4	1 1/4	
2	8 1/2	1 1/2	3 3/8	4 1/8		2.44	2.46	2.50	4	2 1/4	2 1/4	2.38	3/16	1 1/2	
2 1/2	9 3/4	1 3/8	4 1/4	4 3/8		2.94	2.97	3.00	4 1/8	2 1/2	2 1/2	2.88	3/16	1 3/8	
3	9 1/2	1 1/2	5	5		3.57	3.60	3.63	4	2 3/8	2 3/8	3.50	3/16	1 5/8	
4	11 1/2	1 3/4	6 3/16	6 1/4		4.57	4.60	4.63	4 1/2	2 3/4	2 3/4	4.50	7/16	1 3/4	
5	13 3/4	2	7 3/16	7 1/2		5.66	5.69	5.69	5	3 3/8	3 3/8	5.56	3/16	2 1/8	
6	15	2 3/16	8 1/2	9 1/4		6.72	6.75	6.75	5 1/2	3 3/8	3 3/8	6.63	1/2	2 1/4	
8	18 1/2	2 1/2	10 3/8	11 3/4		8.72	8.75	8.75	6 3/4	4	4 1/2	8.63	1/2	2 1/2	
10	21 1/2	2 3/4	12 3/4	14 1/2		10.88	10.92	10.88	7 1/4	4 1/4	5	10.75	1/2	2 13/16	
12	24	3 1/4	15	16 1/2		12.88	12.92	12.94	7 7/8	4 3/4	5 5/8	12.75	1/2	3	
14	25 1/4	3 3/8	16 1/4	17 3/4		14.14	14.18	14.19	8 3/8	5 1/8	6 1/8	14.00	1/2	3 1/4	
16	27 3/4	3 1/2	18 1/2	20		16.16	16.19	16.19	8 1/2	5 1/4	6 1/2	16.00	1/2	3 3/8	
18	31	4	21	22 1/4		18.18	18.20	18.19	9	6	7 1/2	18.00	1/2	3 1/2	
20	33 3/4	4 1/4	23	24 1/2		20.20	20.25	20.19	9 3/4	6 1/4	8 1/4	20.00	1/2	3 3/8	
24	41	5 1/2	27 1/4	29 1/2		24.25	24.25	24.19	11 1/2	8	10 1/2	24.00	1/2	4	
MSS—SP44 Class 900															
26	42 3/4	5 1/2	29 1/2	30 1/2		To be specified by purchaser	26.25	--	--	11 1/4	11 1/4	--	26 3/4	--	--
28	46	5 5/8	31 1/2	32 3/4			28.25	--	--	11 3/4	11 3/4	--	28 11/16	--	--
30	48 1/2	5 3/4	33 3/4	35			30.25	--	--	12 1/4	12 1/4	--	30 3/4	--	--
32	51 3/4	6 1/4	36	37 1/4			32.25	--	--	13	13	--	32 3/4	--	--
34	55	6 1/2	38	39 3/4	34.25		--	--	13 3/4	13 3/4	--	34 13/16	--	--	
36	57 1/2	6 3/4	40 1/4	41 3/4	36.25		--	--	14 1/4	14 1/4	--	36 3/8	--	--	

<sup>Δ</sup> The 1/4" raised face is not included in Thickness C, Length Y or Thread Length T.

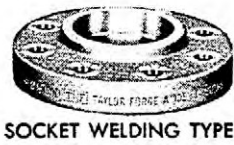

SOCKET WELDING TYPE



REDUCING FLANGES

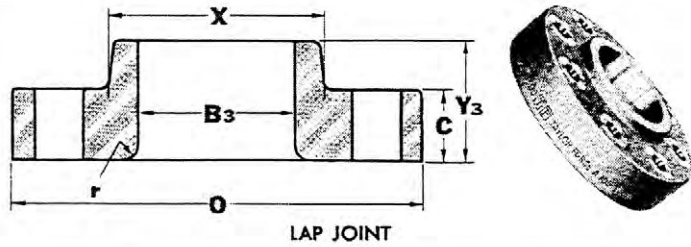

LAP JOINT

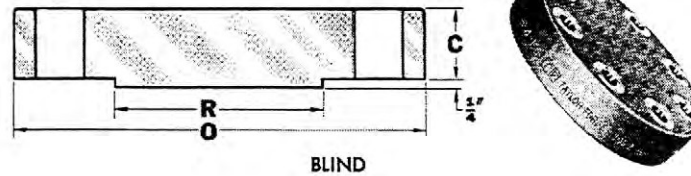

BLIND

Drilling Template and Bolting

Nominal Pipe Size	DRILLING			BOLTING			
	Bolt Circle Diam.	Number of Holes	Diam. of Holes	Diam. of Bolts	Stud Bolt Length+		
					1/4" Raised Face	Male-Female Tongue-Groove	Ring Joint
1/2	3 1/4	4	7/8	3/4	4	3 3/4	4
3/4	3 1/2	4	7/8	3/4	4 1/4	4	4 1/4
1	4	4	1	7/8	4 3/4	4 1/2	4 3/4
1 1/4	4 3/4	4	1	7/8	4 3/4	4 1/2	4 3/4
1 1/2	4 7/8	4	1 1/4	1	5 1/4	5	5 1/4
2	6 1/2	8	1	7/8	5 1/2	5 1/4	5 3/4
2 1/2	7 1/2	8	1 1/4	1	6	5 3/4	6 1/4
3	8	8	1 1/4	1 1/8	6 3/4	6 1/2	7
4	9 1/2	8	1 3/4	1 1/4	7 1/2	7 1/4	7 3/4
5	11 1/2	8	1 3/8	1 1/2	9 1/2	9 1/4	9 3/4
6	12 1/2	12	1 1/2	1 3/8	10	9 3/4	10 1/4
8	15 1/2	12	1 3/4	1 1/2	11 1/4	11	11 3/4
10	19	12	2	1 7/8	13 1/4	13	13 1/2
12	22 1/2	16	2 1/4	2	14 3/4	14 1/2	15 1/4
14	25	16	2 3/4	2 1/4	16	15 3/4	16 3/4
16	27 3/4	16	2 5/8	2 1/2	17 1/2	17 1/4	18 1/2
18	30 1/2	16	2 3/4	2 3/4	19 1/4	19	20 1/4
20	32 3/4	16	3 1/8	3	21	20 3/4	22 1/4
24	39	16	3 3/4	3 1/2	24	23 3/4	25 1/2

All dimensions are in inches.

Weights

Nominal Pipe Size	APPROXIMATE WEIGHT EACH—POUNDS			
	Welding Neck	Slip-on and Thr'd	Lap Joint	Blind
1/2	5	4	4	4
3/4	6	5	5	6
1	9	8	8	8
1 1/4	10	9	9	9
1 1/2	13	12	12	13
2	25	25	25	25
2 1/2	36	36	35	35
3	48	48	47	48
4	73	73	75	73
5	130	130	140	140
6	165	165	170	160
8	275	260	285	300
10	455	435	485	510
12	690	580	630	690
14	940	--	890	975
16	1250	--	1150	1300
18	1625	--	1475	1750
20	2050	--	1775	2225
24	3325	--	2825	3625

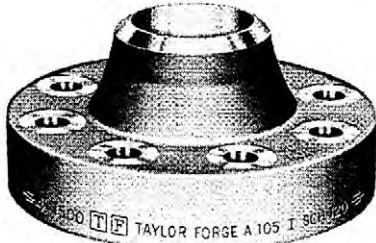
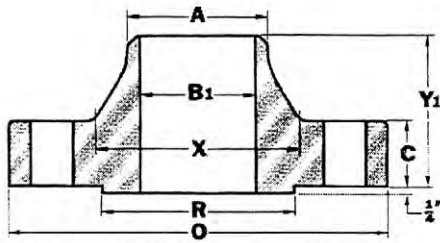

WELDING NECK

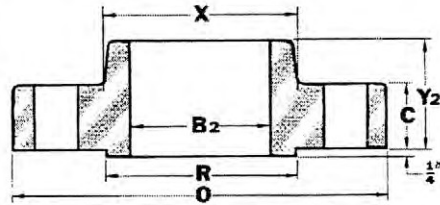

SLIP-ON

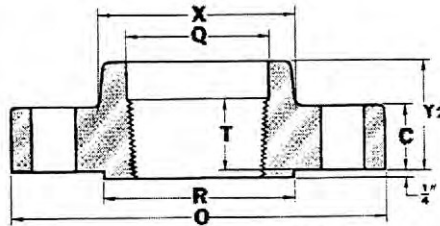

THREADED

Nominal Pipe Size	COMMON DIMENSIONS				BORE				LENGTH THRU HUB			Diam. Hub at Bevel	Radius of Fillet	Thread Length Min. <sup>Δ</sup>
	Outside Diam.	Thick-ness Min. <sup>Δ</sup>	O.D. of Raised Face	Diam. at Base of Hub	Welding Neck	Slip-on	Lap Joint	Counter Bore Min.	Welding Neck <sup>Δ</sup>	Slip-on and Thr'd <sup>Δ</sup>	Lap Joint			
	O	C	R	X	B1	B2	B3	Q	Y1	Y2	Y3			
1/2	4 3/4	7/8	1 1/4	1 1/2	To be specified by purchaser	.88	.90	.93	2 3/8	1 1/4	1 1/4	.84	1/8	3/8
3/4	5 1/8	1	1 11/16	1 3/4		1.09	1.11	1.14	2 3/8	1 3/8	1 3/8	1.05	1/8	1
1	5 7/8	1 1/4	2	2 1/8		1.36	1.38	1.41	2 7/8	1 3/8	1 3/8	1.32	1/8	1 1/8
1 1/4	6 1/4	1 1/4	2 1/2	2 1/2		1.70	1.72	1.75	2 7/8	1 3/4	1 3/8	1.66	3/16	1 3/16
1 1/2	7	1 1/4	2 3/8	2 3/4		1.95	1.97	1.99	3 1/4	1 3/4	1 3/4	1.90	1/4	1 1/4
2	8 1/2	1 1/2	3 3/8	4 1/8		2.44	2.46	2.50	4	2 1/4	2 1/4	2.38	3/16	1 1/2
2 1/2	9 3/8	1 3/4	4 1/8	4 7/8		2.94	2.97	3.00	4 1/2	2 1/2	2 1/2	2.88	3/16	1 7/8
3	10 1/2	1 7/8	5	5 1/4		3.57	3.60	3.63	4 3/4	2 7/8	2 7/8	3.50	3/8	2
4	12 1/4	2 1/8	6 3/16	6 3/8		4.57	4.60	4.63	4 7/8	3 1/16	3 1/16	4.50	7/16	2 1/4
5	14 3/4	2 3/8	7 3/8	7 3/4		5.66	5.69	5.69	6 1/8	4 3/8	4 3/8	5.56	7/16	2 1/2
6	15 1/2	3 1/4	8 1/2	9		6.72	6.75	6.75	6 3/4	4 11/16	4 11/16	6.63	1/2	2 3/4
8	19	3 3/8	10 3/8	11 1/2		8.72	8.75	8.75	8 3/8	5 5/8	5 5/8	8.63	1/2	3
10	23	4 1/4	12 3/4	14 1/2		10.88	10.92	10.88	10	6 1/4	7	10.75	1/2	3 3/16
12	26 1/2	4 3/4	15	17 3/4		12.88	12.92	12.94	11 1/2	7 1/8	8 3/8	12.75	1/2	3 3/8
14	29 1/2	5 1/4	16 1/4	19 1/2		--	14.18	--	11 3/4	--	9 1/2	14.00	1/2	--
16	32 1/2	5 3/4	18 1/2	21 3/4		--	16.19	--	12 1/4	--	10 1/4	16.00	1/2	--
18	36	6 3/8	21	23 1/2	--	18.20	--	12 3/4	--	10 7/8	18.00	1/2	--	
20	38 3/4	7	23	25 1/4	--	20.25	--	14	--	11 1/2	20.00	1/2	--	
24	46	8	27 1/4	30	--	24.25	--	16	--	13	24.00	1/2	--	

<sup>Δ</sup> The 1/4" raised face is not included in Thickness C, Length Y or Thread Length T.





REDUCING FLANGES

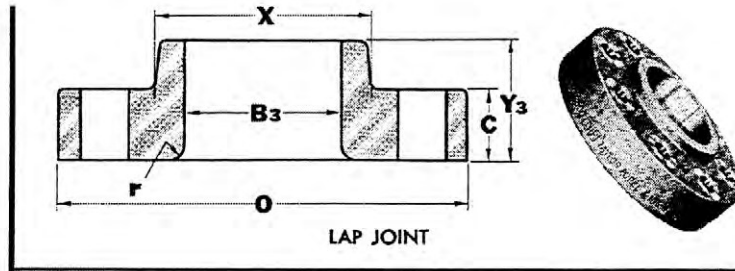

LAP JOINT

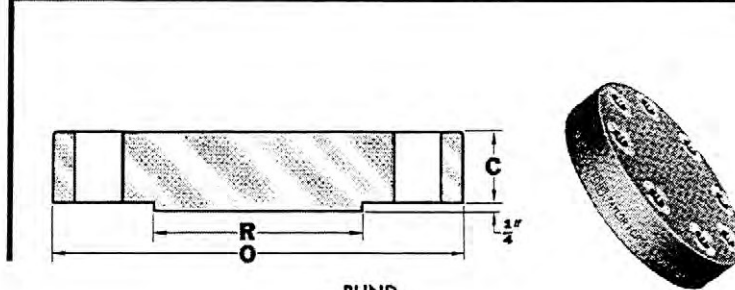

BLIND

Drilling Template and Bolting

Nominal Pipe Size	DRILLING			BOLTING			
	Bolt Circle Diam.	Number of Holes	Diam. of Holes	Diam. of Bolts	Stud Bolt Length+		
					1/4" Raised Face	Male-Female Tongue-Groove	Ring Joint
1/2	3 1/2	4	7/8	3/4	4 3/4	4 1/2	4 3/4
3/4	3 3/4	4	7/8	3/4	4 3/4	4 1/2	4 3/4
1	4 1/4	4	1	7/8	5 1/4	5	5 1/4
1 1/4	5 1/4	4	1 1/8	1	5 3/4	5 1/2	6
1 1/2	5 3/4	4	1 1/4	1 1/8	6 1/2	6 1/4	6 3/4
2	6 3/4	8	1 1/8	1	6 3/4	6 1/2	7
2 1/2	7 3/4	8	1 1/4	1 1/8	7 1/2	7 1/4	7 3/4
3	9	8	1 3/8	1 1/4	8 1/2	8 1/4	8 3/4
4	10 3/4	8	1 5/8	1 1/2	9 3/4	9 1/2	10 1/4
5	12 3/4	8	1 7/8	1 3/4	11 1/2	11 1/4	12 1/4
6	14 1/2	8	2 1/4	2	13 1/2	13 1/4	14
8	17 1/4	12	2 1/4	2	15	14 3/4	15 1/2
10	21 1/4	12	2 5/8	2 1/2	19	18 3/4	20
12	24 3/4	12	2 3/4	2 3/4	21	20 3/4	22

All dimensions are in inches.

Weights

Nominal Pipe Size	APPROXIMATE WEIGHT EACH—POUNDS			
	Welding Neck	Slip-on and Thr'd	Lap Joint	Blind
1/2	7	7	7	7
3/4	8	8	8	8
1	12	11	11	11
1 1/4	17	16	16	17
1 1/2	25	22	22	23
2	42	38	37	39
2 1/2	52	55	53	56
3	94	83	80	86
4	145	125	120	135
5	245	210	205	225
6	380	325	315	345
8	580	485	470	530
10	1075	930	900	1025
12	1525	1100	1100	1300



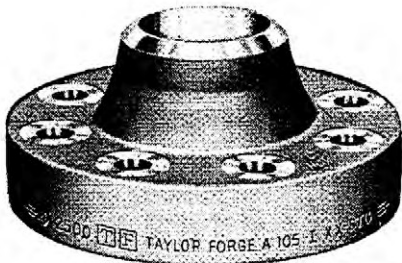
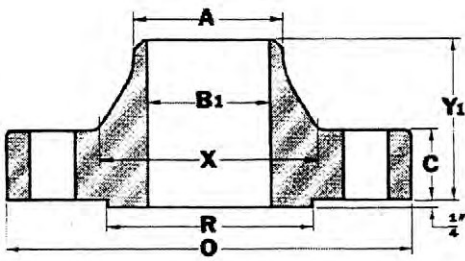

WELDING NECK

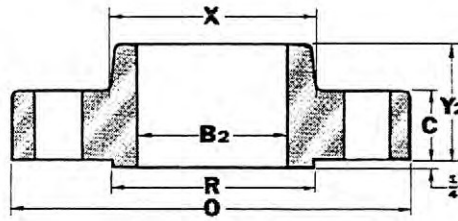

SLIP-ON

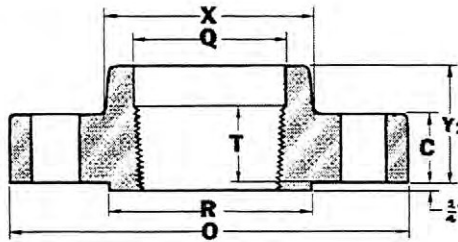

THREADED



Nominal Pipe Size	COMMON DIMENSIONS				BORE				LENGTH THRU HUB			Diam. Hub at Bevel	Radius of Fillet	Thread Length Min. <sup>Δ</sup>
	Outside Diam.	Thick-ness Min. <sup>Δ</sup>	O.D. of Raised Face	Diam. at Base of Hub	Welding Neck	Slip-on	Lap Joint	Counter Bore Min.	Welding Neck <sup>Δ</sup>	Slip-on and Thr'd <sup>Δ</sup>	Lap Joint			
	O	C	R	X	B1	B2	B3	Q	Y1	Y2	Y3			
1/2	5 1/4	1 1/16	1 3/8	1 11/16	To be specified by purchaser	.88	.90	.93	2 7/8	1 1/16	1 1/16	.84	1/8	1 1/8
3/4	5 1/2	1 1/4	1 11/16	2		1.09	1.11	1.14	3 1/8	1 11/16	1 11/16	1.05	1/8	1 1/4
1	6 1/4	1 3/8	2	2 1/4		1.36	1.38	1.41	3 1/2	1 7/8	1 7/8	1.32	1/8	1 3/8
1 1/4	7 1/4	1 1/2	2 1/2	2 7/8		1.70	1.72	1.75	3 3/4	2 1/8	2 1/8	1.66	3/16	1 1/2
1 1/2	8	1 3/4	2 7/8	3 1/8		1.95	1.97	1.99	4 3/8	2 3/8	2 3/8	1.90	1/4	1 3/4
2	9 1/4	2	3 3/8	3 3/4		2.44	2.46	2.50	5	2 3/4	2 3/4	2.38	3/16	2
2 1/2	10 1/2	2 1/4	4 1/8	4 1/2		2.94	2.97	3.00	5 5/8	3 1/8	3 1/8	2.88	3/16	2 1/4
3	12	2 5/8	5	5 1/4		3.57	3.60	3.63	6 3/8	3 3/8	3 3/8	3.50	3/8	2 1/2
4	14	3	6 1/16	6 1/2		4.57	4.60	4.63	7 1/2	4 1/4	4 1/4	4.50	7/16	2 3/4
5	16 1/2	3 3/8	7 1/8	8		5.66	5.69	5.69	9	5 5/8	5 5/8	5.56	7/16	3
6	19	4 1/4	8 1/2	9 1/4		6.72	6.75	6.75	10 3/4	6	6	6.63	1/2	3 1/4
8	21 1/4	5	10 5/8	12		8.72	8.75	8.75	12 1/2	7	7	8.63	1/2	3 3/4
10	26 1/2	6 1/2	12 3/4	14 3/4	10.88	10.92	10.88	16 1/2	9	9	10.75	1/2	4 1/4	
12	30	7 1/4	15	17 3/8	12.88	12.92	12.94	18 1/4	10	10	12.75	1/2	4 3/4	

<sup>Δ</sup> The 1/4" raised face is not included in Thickness C, Length Y or Thread Length T.



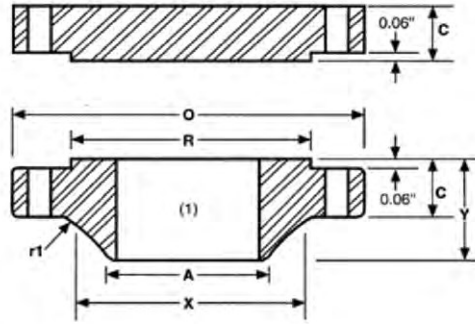

Class 150

Nom. Size	O	WNF	BLIND	Y	X	A	R	Diam. of bolt circle	No. of holes	Diam. of bolt hole	Diam. of bolt	R1
in. 26"	34.25	2.69	2.69	4.75	26.62	26	29.5	31.75	24	1.38	1 1/4	0.38
mm.	870	68.3	68.3	120.7	676.1	660.4	749.3	806.5		35.1	31.8	9.7
in. 28"	36.5	2.81	2.81	4.94	28.62	28	31.5	34	28	1.38	1 1/4	0.44
mm.	927.1	71.4	71.4	125.5	726.9	711.2	800.1	863.6		35.1	31.8	11.2
in. 30"	38.75	2.94	2.94	5.38	30.75	30	33.75	36	28	1.38	1 1/4	0.44
mm.	984.3	74.7	74.7	136.7	781.1	762	857.3	914.4		35.1	31.8	11.2
in. 32"	41.75	3.19	3.19	5.69	32.75	32	36	38.5	28	1.62	1 1/2	0.44
mm.	1060.5	81	81	144.5	831.9	812.8	914.4	977.9		41.1	38.1	11.2
in. 34"	43.75	3.25	3.25	5.88	34.75	34	38	40.5	32	1.62	1 1/2	0.5
mm.	1111.3	82.6	82.6	149.4	882.7	863.6	965.2	1028.7		41.1	38.1	12.7
in. 36"	46	3.56	3.56	6.19	36.75	36	40.25	42.75	32	1.62	1 1/2	0.5
mm.	1168.4	90.4	90.4	157.2	933.5	914.4	1022.4	1085.9		41.1	38.1	12.7
in. 38"	48.75	3.44	3.44	6.19	39	38	42.25	45.25	32	1.62	1 1/2	0.5
mm.	1238.3	87.4	87.4	157.2	990.6	965.2	1073.2	1149.4		41.1	38.1	12.7
in. 40"	50.75	3.56	3.56	6.44	41	40	44.25	47.25	36	1.62	1 1/2	0.5
mm.	1289.1	90.4	90.4	163.6	1041.4	1016	1124	1200.2		41.1	38.1	12.7
in. 42"	53	3.81	3.81	6.75	43	42	47	49.5	36	1.62	1 1/2	0.5
mm.	1346.2	96.8	96.8	171.5	1092.2	1066.8	1193.8	1257.3		41.1	38.1	12.7
in. 44"	55.25	4	4	7	45	44	49	51.75	40	1.62	1 1/2	0.5
mm.	1403.4	101.6	101.6	177.8	1143	1117.6	1244.6	1314.5		41.1	38.1	12.7
in. 46"	57.25	4.06	4.06	7.31	47.12	46	51	53.75	40	1.62	1 1/2	0.5
mm.	1454.2	103.1	103.1	185.7	1196.8	1168.4	1295.4	1365.3		41.1	38.1	12.7
in. 48"	59.5	4.25	4.25	7.56	49.12	48	53.5	56	44	1.62	1 1/2	0.5
mm.	1511.3	108	108	192	1247.6	1219.2	1358.9	1422.4		41.1	38.1	12.7
in. 50"	61.75	4.38	4.38	8	51.25	50	55.5	58.25	44	1.88	1 3/4	0.5
mm.	1568.5	111.3	111.3	203.2	1301.8	1270	1409.7	1479.6		47.8	44.5	12.7
in. 52"	64	4.56	4.56	8.25	53.25	52	57.5	60.25	44	1.88	1 3/4	0.5
mm.	1625.6	115.8	115.8	209.6	1352.6	1320.8	1460.5	1530.4		47.8	44.5	12.7
in. 54"	66.25	4.75	4.75	8.5	55.25	54	59.5	62.75	44	1.88	1 3/4	0.5
mm.	1682.8	120.7	120.7	215.9	1403.4	1371.6	1511.3	1593.9		47.8	44.5	12.7
in. 56"	68.75	4.88	4.88	9	57.38	56	62	65	48	1.88	1 3/4	0.5
mm.	1746.3	124	124	228.6	1457.5	1422.4	1574.8	1651		47.8	44.5	12.7
in. 58"	71	5.06	5.06	9.25	59.38	58	64	67.25	48	1.88	1 3/4	0.5
mm.	1803.4	128.5	128.5	235	1508.3	1473.2	1625.6	1708.2		47.8	44.5	12.7
in. 60"	73	5.19	5.19	9.44	61.38	60	66	69.25	52	1.88	1 3/4	0.5
mm.	1854.2	131.8	131.8	239.8	1559.1	1524	1676.4	1759		47.8	44.5	12.7

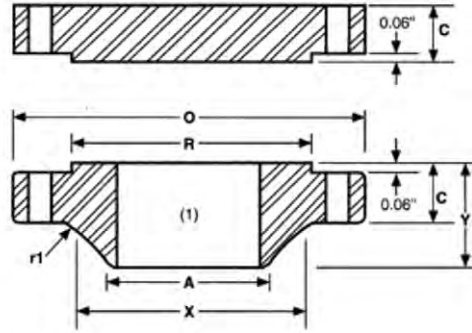

Class 300

Nom. Size	O	WNF	BLIND	Y	X	A	R	Diam. of bolt circle	No. of holes	Diam. of bolt hole	Diam. of bolt	R1
in. 26"	38.25	3.12	3.31	7.25	28.38	26	29.5	34.5	28	1.75	1 5/8	0.38
mm.	971.6	79.2	84.1	184.2	720.9	660.4	749.3	876.3		44.5	41.4	9.7
in. 28"	40.75	3.38	3.56	7.75	30.5	28	31.5	37	28	1.75	1 5/8	0.44
mm.	1035.1	85.9	90.4	196.9	774.7	711.2	800.1	939.8		44.5	41.4	11.2
in. 30"	43	3.62	3.75	8.25	32.56	30	33.75	39.25	28	1.88	1 3/4	0.44
mm.	1092.2	91.9	95.3	209.6	827	762	857.3	997		47.8	44.5	11.2
in. 32"	45.25	3.88	3.94	8.75	34.69	32	36	41.5	28	2	1 7/8	0.44
mm.	1149.4	98.6	100.1	222.3	881.1	812.8	914.4	1054.1		50.8	47.8	11.2
in. 34"	47.5	4	4.12	9.12	36.88	34	38	43.5	28	2	1 7/8	0.5
mm.	1206.5	101.6	104.6	231.6	936.8	863.6	965.2	1104.9		50.8	47.8	12.7
in. 36"	50	4.12	4.38	9.5	39	36	40.25	46	32	2.12	2	0.5
mm.	1270	104.6	111.3	241.3	990.6	914.4	1022.4	1168.4		53.8	50.8	12.7
in. 38"	46	4.25	4.25	7.12	39.12	38	40.5	43	32	1.62	1 1/2	0.5
mm.	1168.4	108	108	180.8	993.6	965.2	1028.7	1092.2		41.1	38.1	12.7
in. 40"	48.75	4.5	4.5	7.62	41.12	40	42.75	45.5	32	1.75	1 5/8	0.5
mm.	1238.3	114.3	114.3	193.5	1044.4	1016	1085.9	1155.7		44.5	41.4	12.7
in. 42"	50.75	4.69	4.69	7.88	43.25	42	44.75	47.5	32	1.75	1 5/8	0.5
mm.	1289.1	119.1	119.1	200.2	1098.6	1066.8	1136.7	1206.5		44.5	41.4	12.7
in. 44"	53.25	4.88	4.88	8.12	45.25	44	47	49.75	32	1.88	1 3/4	0.5
mm.	1352.6	124	124	206.2	1149.4	1117.6	1193.8	1263.7		47.8	44.5	12.7
in. 46"	55.75	5.06	5.06	8.5	47.38	46	49	52	28	2	1 7/8	0.5
mm.	1416.1	128.5	128.5	215.9	1203.5	1168.4	1244.6	1320.8		50.8	47.8	12.7
in. 48"	57.75	5.25	5.25	8.81	49.38	48	51.25	54	32	2	1 7/8	0.5
mm.	1466.9	133.4	133.4	223.8	1254.3	1219.2	1301.8	1371.6		50.8	47.8	12.7
in. 50"	60.25	5.5	5.5	9.12	51.38	50	53.5	56.25	32	2.12	2	0.5
mm.	1530.4	139.7	139.7	231.6	1305.1	1270	1358.9	1428.8		53.8	50.8	12.7
in. 52"	62.25	5.69	5.69	9.38	53.38	52	55.5	58.25	32	2.12	2	0.5
mm.	1581.2	144.5	144.5	238.3	1355.9	1320.8	1409.7	1479.6		53.8	50.8	12.7
in. 54"	65.25	6	6	9.94	55.5	54	57.75	61	28	2.38	2 1/4	0.5
mm.	1657.4	152.4	152.4	252.5	1409.7	1371.6	1466.9	1549.4		60.5	57.2	12.7
in. 56"	67.25	6.06	6.06	10.25	57.62	56	59.75	63	28	2.38	2 1/4	0.5
mm.	1708.2	153.9	153.9	260.4	1463.5	1422.4	1517.7	1600.2		60.5	57.2	12.7
in. 58"	69.25	6.25	6.25	10.5	59.62	58	62	65	32	2.38	2 1/4	0.5
mm.	1759	158.8	158.8	266.7	1514.3	1473.2	1574.8	1651		60.5	57.2	12.7
in. 60"	71.25	6.44	6.44	10.75	61.62	60	64	67	32	2.38	2 1/4	0.5
mm.	1809.8	163.6	163.6	273.1	1565.1	1524	1625.6	1701.8		60.5	57.2	12.7



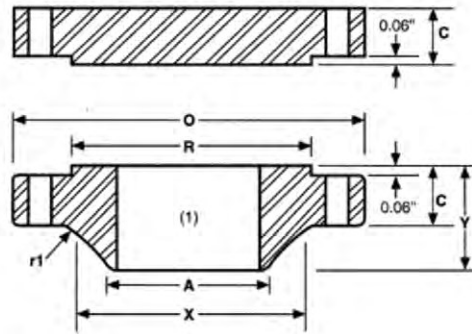

Class 400

Nom. Size	O	WNF	BLIND	Y	X	A	R	Diam. of bolt circle	No. of holes	Diam. of bolt hole	Diam. of bolt	R1
in. 26"	38.25	3.5	3.88	7.62	28.62	26	29.5	34.5	28	1.88	1 3/4	0.44
mm.	971.6	88.9	98.6	193.5	726.9	660.4	749.3	876.3		47.8	44.5	11.2
in. 28"	40.75	3.75	4.12	8.12	30.81	28	31.5	37	28	2	1 7/8	0.5
mm.	1035.1	95.3	104.6	206.2	782.6	711.2	800.1	939.8		50.8	47.6	12.7
in. 30"	43	4	4.38	8.62	32.94	30	33.75	39.25	28	2.12	2	0.5
mm.	1092.2	101.6	111.3	218.9	836.7	762	857.3	997		53.8	50.8	12.7
in. 32"	45.25	4.25	4.56	9.12	35	32	36	41.25	28	2.12	2	0.5
mm.	1149.4	108	115.8	231.6	889	812.8	914.4	1047.8		53.8	50.8	12.7
in. 34"	47.5	4.38	4.81	9.5	37.19	34	38	43.5	28	2.12	2	0.56
mm.	1206.5	111.3	122.2	241.3	944.6	863.6	965.2	1104.9		53.8	50.8	14.2
in. 36"	50	4.5	5.06	9.88	39.38	36	40.25	46	32	2.12	2	0.56
mm.	1270	114.3	128.5	251	1000.3	914.4	1022.4	1168.4		53.8	50.8	14.2
in. 38"	47.5	4.88	4.88	8.12	39.5	38	40.75	44	32	1.88	1 3/4	0.56
mm.	1206.5	124	124	206.2	1003.3	965.2	1035.1	1117.6		47.8	44.5	14.2
in. 40"	50	5.12	5.12	8.5	41.5	40	43	46.25	32	2	1 7/8	0.56
mm.	1270	130	130	215.9	1054.1	1016	1092.2	1174.8		50.8	47.6	14.2
in. 42"	52	5.25	5.25	8.81	43.62	42	45	48.25	32	2	1 7/8	0.56
mm.	1320.8	133.4	133.4	223.8	1107.9	1066.8	1143	1225.6		50.8	47.6	14.2
in. 44"	54.5	5.5	5.5	9.18	45.62	44	47.25	50.5	32	2.12	2	0.56
mm.	1384.3	139.7	139.7	233.2	1158.7	1117.6	1200.2	1282.7		53.8	50.8	14.2
in. 46"	56.75	5.75	5.75	9.62	47.75	46	49.5	52.75	36	2.12	2	0.56
mm.	1441.5	146.1	146.1	244.3	1212.9	1168.4	1257.3	1339.9		53.8	50.8	14.2
in. 48"	59.5	6	6	10.12	49.88	48	51.5	55.25	28	2.38	2 1/4	0.56
mm.	1511.3	152.4	152.4	257	1267	1219.2	1308.1	1403.4		60.5	57.2	14.2
in. 50"	61.75	6.19	6.25	10.56	52	50	53.62	57.5	32	2.38	2 1/4	0.56
mm.	1568.5	157.2	158.8	268.2	1320.8	1270	1361.9	1460.5		60.5	57.2	14.2
in. 52"	63.75	6.38	6.44	10.88	54	52	55.62	59.5	32	2.38	2 1/4	0.56
mm.	1619.3	162.1	163.6	276.4	1371.6	1320.8	1412.7	1511.3		60.5	57.2	14.2
in. 54"	67	6.69	6.75	11.38	56.12	54	57.88	62.25	28	2.62	2 1/2	0.56
mm.	1701.8	169.9	171.5	289.1	1425.4	1371.6	1470.2	1581.2		66.5	63.5	14.2
in. 56"	69	6.88	6.94	11.75	58.25	56	60.12	64.25	32	2.62	2 1/2	0.56
mm.	1752.6	174.8	176.3	298.5	1479.6	1422.4	1527	1632		66.5	63.5	14.2
in. 58"	71	7	7.12	12.06	60.25	58	62.12	66.25	32	2.62	2 1/2	0.56
mm.	1803.4	177.8	180.8	306.3	1530.4	1473.2	1577.8	1682.8		66.5	63.5	14.2
in. 60"	74.25	7.31	7.44	12.56	62.38	60	64.38	69	32	2.88	2 5/8	0.56
mm.	1886	185.7	189	319	1584.5	1524	1635.3	1752.6		73.2	66.7	14.2

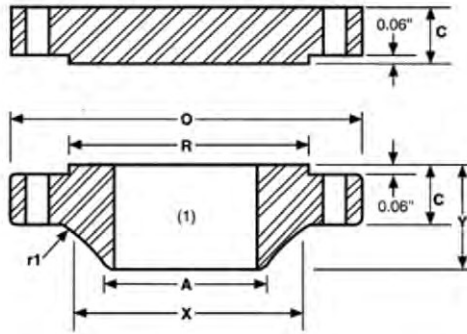

Class 600

Nom. Size	O	WNF	BLIND	Y	X	A	R	Diam. of bolt circle	No. of holes	Diam. of bolt hole	Diam. of bolt	R1
in. 26"	40	4.25	4.94	8.75	29.44	26	29.5	36	28	2	1 7/8	0.5
mm.	1016	108	125.5	222.3	747.8	660.4	749.3	914.4		50.8	47.6	12.7
in. 28"	42.25	4.38	5.19	9.25	31.62	28	31.5	38	28	2.12	2	0.5
mm.	1073.2	111.3	131.8	235	803.1	711.2	800.1	965.2		53.8	50.8	12.7
in. 30"	44.5	4.5	5.5	9.75	33.94	30	33.75	40.25	28	2.12	2	0.5
mm.	1130.3	114.3	139.7	247.7	862.1	762	857.3	1022.4		53.8	50.8	12.7
in. 32"	47	4.62	5.81	10.25	36.12	32	36	42.5	28	2.38	2 1/4	0.5
mm.	1193.8	117.3	147.6	260.4	917.4	812.8	914.4	1079.5		60.5	57.2	12.7
in. 34"	49	4.75	6.06	10.62	38.31	34	38	44.5	28	2.38	2 1/4	0.56
mm.	1244.6	120.7	153.9	269.7	973.1	863.6	965.2	1130.3		60.5	57.2	14.2
in. 36"	51.75	4.88	6.38	11.12	40.62	36	40.25	47	28	2.62	2 1/2	0.56
mm.	1314.5	124	162.1	282.4	1031.7	914.4	1022.4	1193.8		66.5	63.5	14.2
in. 38"	50	6	6.12	10	40.25	38	41.5	45.75	28	2.38	2 1/4	0.56
mm.	1270	152.4	155.4	254	1022.4	965.2	1054.1	1162.1		60.5	57.2	14.2
in. 40"	52	6.25	6.38	10.38	42.25	40	43.75	47.75	32	2.38	2 1/4	0.56
mm.	1320.8	158.8	162.1	263.7	1073.2	1016	1111.3	1212.9		60.5	57.2	14.2
in. 42"	55.25	6.62	6.75	11	44.38	42	46	50.5	28	2.62	2 1/2	0.56
mm.	1403.4	168.1	171.5	279.4	1127.3	1066.8	1168.4	1282.7		66.5	63.5	14.2
in. 44"	57.25	6.81	7	11.38	46.5	44	48.25	52.5	32	2.62	2 1/2	0.56
mm.	1454.2	173	177.8	289.1	1181.1	1117.6	1225.6	1333.5		66.5	63.5	14.2
in. 46"	59.5	7.06	7.31	11.81	48.62	46	50.25	54.75	32	2.62	2 1/2	0.56
mm.	1511.3	179.3	185.7	300	1234.9	1168.4	1276.4	1390.7		66.5	63.5	14.2
in. 48"	62.75	7.44	7.69	12.44	50.75	48	52.5	57.5	32	2.88	2 3/4	0.56
mm.	1593.9	189	195.3	316	1289.1	1219.2	1333.5	1460.5		73.2	69.9	14.2
in. 50"	65.75	7.75	8	12.94	52.88	50	54.5	60	28	3.12	3	0.56
mm.	1670.1	196.9	203.2	328.7	1343.2	1270	1384.3	1524		79.2	76.2	14.2
in. 52"	67.75	8	8.25	13.25	54.88	52	56.5	62	32	3.12	3	0.56
mm.	1720.9	203.2	209.6	336.6	1394	1320.8	1435.1	1574.8		79.2	76.2	14.2
in. 54"	70	8.25	8.56	13.75	57	54	58.75	64.25	32	3.12	3	0.56
mm.	1778	209.6	217.4	349.3	1447.8	1371.6	1492.3	1632		79.2	76.2	14.2
in. 56"	73	8.56	8.88	14.25	59.12	56	60.75	66.75	32	3.38	3 1/4	0.62
mm.	1854.2	217.4	225.6	362	1501.6	1422.4	1543.1	1695.5		85.9	82.6	15.7
in. 58"	75	8.75	9.12	14.56	61.12	58	63	68.75	32	3.38	3 1/4	0.62
mm.	1905	222.3	231.6	369.8	1552.4	1473.2	1600.2	1746.3		85.9	82.6	15.7
in. 60"	78.5	9.19	9.56	15.31	63.38	60	65.25	71.75	28	3.62	3 1/2	0.69
mm.	1993.9	233.4	242.8	388.9	1609.9	1524	1657.4	1822.5		91.9	88.9	17.5



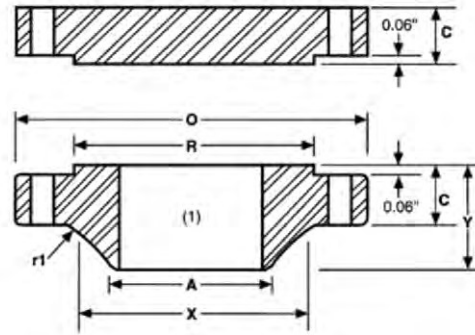

Class 900

Nom. Size	O	WNF	BLIND	Y	X	A	R	Diam. of bolt circle	No. of holes	Diam. of bolt hole	Diam. of bolt	R1
in. 26"	42.75	5.5	6.31	11.25	30.5	26	29.5	37.5	20	2.88	2 3/4	0.44
mm.	1085.9	139.7	160.3	285.8	774.7	660.4	749.3	952.5		73.2	69.9	11.2
in. 28"	46	5.62	6.75	11.75	32.75	28	31.5	40.25	20	3.12	3	0.5
mm.	1168.4	142.7	171.5	298.5	831.9	711.2	800.1	1022.4		79.2	76.2	12.7
in. 30"	48.5	5.88	7.18	12.25	35	30	33.75	42.75	20	3.12	3	0.5
mm.	1231.9	149.4	182.4	311.2	889	762	857.3	1085.9		79.2	76.2	12.7
in. 32"	51.75	6.25	7.62	13	37.25	32	36	45.5	20	3.38	3 1/4	0.5
mm.	1314.5	158.8	193.5	330.2	946.2	812.8	914.4	1155.7		85.9	82.6	12.7
in. 34"	55	6.5	8.06	13.75	39.62	34	38	48.25	20	3.62	3 1/2	0.56
mm.	1397	165.1	204.7	349.3	1006.3	863.6	965.2	1225.6		91.9	88.9	14.2
in. 36"	57.5	6.75	8.44	14.25	41.88	36	40.25	50.75	20	3.62	3 1/2	0.56
mm.	1460.5	171.5	214.4	362	1063.8	914.4	1022.4	1289.1		91.9	88.9	14.2
in. 38"	57.5	7.5	8.5	13.88	42.25	38	43.25	50.75	20	3.62	3 1/2	0.75
mm.	1460.5	190.5	215.9	352.6	1073.2	965.2	1098.6	1289.1		91.9	88.9	19.1
in. 40"	59.5	7.75	8.81	14.31	44.38	40	45.75	52.75	24	3.62	3 1/2	0.81
mm.	1511.3	196.9	223.8	363.5	1127.3	1016	1162.1	1339.9		91.9	88.9	20.6
in. 42"	61.5	8.12	9.12	14.62	46.31	42	47.75	54.75	24	3.62	3 1/2	0.81
mm.	1562.1	206.2	231.6	371.3	1176.3	1066.8	1212.9	1390.7		91.9	88.9	20.6
in. 44"	64.88	8.44	9.56	15.38	48.62	44	50	57.62	24	3.88	3 3/4	0.88
mm.	1648	214.4	242.8	390.7	1234.9	1117.6	1270	1463.5		98.6	95.3	22.4
in. 46"	68.25	8.88	10.86	16.18	50.88	46	52.5	60.5	24	4.12	4	0.88
mm.	1733.6	225.6	275.8	411	1292.4	1168.4	1333.5	1536.7		104.6	101.6	22.4
in. 48"	70.25	9.19	10.38	16.5	52.88	48	54.5	62.5	24	4.12	4	0.94
mm.	1784.4	233.4	263.7	419.1	1343.2	1219.2	1384.3	1587.5		104.6	101.6	23.9

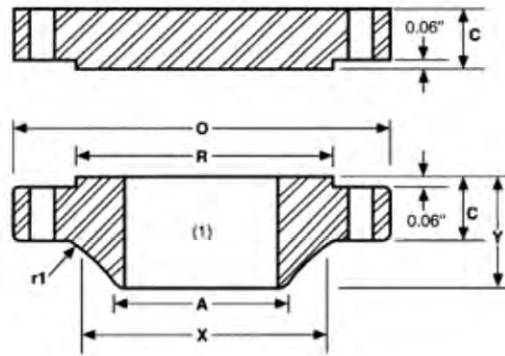

Class 75

Nom. Size	O	WNF	BLIND	Y	X	A	R.	Diam. of bolt circle	No. of holes	Diam. of bolt hole	Diam. of bolt	R1
in. 26"	30	1.31	1.31	2.31	26.62	26.06	27.75	28.5	36	0.75	05/08/07	0.31
mm.	762	33.3	33.3	58.7	676.1	661.9	704.9	723.9		19.1	15.9	7.9
in. 28"	32	1.31	1.31	2.44	28.62	28.06	29.75	30.5	40	0.75	05/08/07	0.31
mm.	812.8	33.3	33.3	62	726.9	712.7	755.7	774.7		19.1	15.9	7.9
in. 30"	34	1.31	1.31	2.56	30.62	30.06	31.75	32.5	44	0.75	05/08/07	0.31
mm.	863.6	33.3	33.3	65	777.7	763.5	806.5	825.5		19.1	15.9	7.9
in. 32"	36	1.38	1.38	2.75	32.62	32.06	33.75	34.5	48	0.75	05/08/07	0.31
mm.	914.4	35.1	35.1	69.9	828.5	814.3	857.3	876.3		19.1	15.9	7.9
in. 34"	38	1.38	1.38	2.88	34.62	34.06	35.75	36.5	52	0.75	05/08/07	0.31
mm.	965.2	35.1	35.1	73.2	879.3	865.1	908.1	927.1		19.1	15.9	7.9
in. 36"	40.69	1.44	1.44	2.38	36.81	36.06	38	39.06	40	0.88	03/04/07	0.38
mm.	1033.5	36.6	36.6	60.5	935	915.9	965.2	992.1		22.4	19.1	9.7
in. 38"	42.69	1.5	1.5	3.5	38.81	38.06	40	41.06	40	0.88	03/04/07	0.38
mm.	1084.3	38.1	38.1	88.9	985.8	966.7	1016	1042.9		22.4	19.1	9.7
in. 40"	44.69	1.5	1.5	3.62	40.81	40.06	42	43.06	44	0.88	03/04/07	0.38
mm.	1135.1	38.1	38.1	91.9	1036.6	1017.5	1066.8	1093.7		22.4	19.1	9.7
in. 42"	46.69	1.56	1.56	3.75	42.81	42.06	44	45.06	48	0.88	03/04/07	0.38
mm.	1185.9	39.6	39.6	95.3	1087.4	1068.3	1117.6	1144.5		22.4	19.1	9.7
in. 44"	49.25	1.69	1.69	4.12	44.88	44.06	46.25	47.38	36	1	07/08/07	0.38
mm.	1251	42.9	42.9	104.6	1140	1119.1	1174.8	1203.5		25.4	22.2	9.7
in. 46"	51.25	1.75	1.75	4.25	46.88	46.06	48.25	49.38	40	1	07/08/07	0.38
mm.	1301.8	44.5	44.5	108	1190.8	1169.9	1225.6	1254.3		25.4	22.2	9.7
in. 48"	53.25	1.81	1.81	4.38	48.88	48.06	50.25	51.38	44	1	07/08/07	0.38
mm.	1352.6	46	46	111.3	1241.6	1220.7	1276.4	1305.1		25.4	22.2	9.7
in. 50"	55.25	1.88	1.88	4.56	50.94	50.06	52.25	53.38	44	1	07/08/07	0.38
mm.	1403.4	47.8	47.8	115.8	1293.9	1271.5	1327.2	1355.9		25.4	22.2	9.7

continued on next page



Class 75 continued

in.	52"	57.38	1.88	1.88	4.75	52.94	52.06	54.25	55.5	48	1	07/08/07	0.38
mm.		1457.5	47.8	47.8	120.7	1344.7	1322.3	1378	1409.7		25.4	22.2	9.7
in.	54"	59.38	1.94	1.94	4.94	55	54.06	56.25	57.5	48	1	07/08/07	0.38
mm.		1508.3	49.3	49.3	125.5	1397	1373.1	1428.8	1460.5		25.4	22.2	9.7
in.	56"	62	2	2	5.31	57.12	56.06	58.25	59.88	40	1.12	1	0.44
mm.		1574.8	50.8	50.8	134.9	1450.8	1423.9	1479.6	1521		28.4	25.4	11.2
in.	58"	64	2.06	2.06	5.44	59.12	58.06	60.5	61.88	44	1.12	1	0.44
mm.		1625.6	52.3	52.3	138.2	1501.6	1474.7	1536.7	1571.8		28.4	25.4	11.2
in.	60"	66	2.19	2.19	5.69	61.12	60.06	62.5	63.88	44	1.12	1	0.44
mm.		1676.4	55.6	55.6	144.5	1552.4	1525.5	1587.5	1622.6		28.4	25.4	11.2



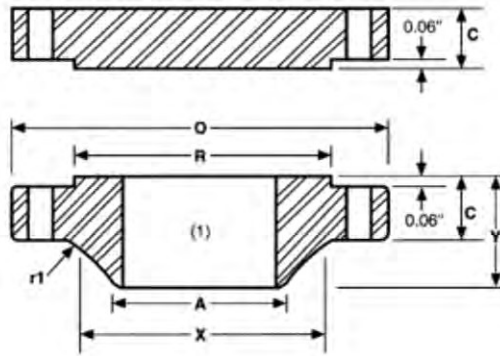

Class 150

Nom. Size	Outside diam. of flange	Thick. of flange	Length through hub	Diam. of hub	Hub diam. top	Raised face diam.	Diam. of bolt circle	No. of holes	Diam. of bolt hole	Diam. of bolt	Fillet radius min.
in. 26"	30.94	1.62	3.5	26.94	26.06	28	29.31	36	0.88	03/04/07	0.38
mm.	785.9	41.1	88.9	684.3	661.9	711.2	744.5		22.4	19.1	9.7
in. 28"	32.94	1.75	3.75	28.94	28.06	30	31.31	40	0.88	03/04/07	0.38
mm.	836.7	44.5	95.3	735.1	712.7	762	795.3		22.4	19.1	9.7
in. 30"	34.94	1.75	3.94	31	30.06	32	33.31	44	0.88	03/04/07	0.38
mm.	887.5	44.5	100.1	787.4	763.5	812.8	846.1		22.4	19.1	9.7
in. 32"	37.06	1.81	4.25	33.06	32.06	34	35.44	48	0.88	03/04/07	0.38
mm.	941.3	46	108	839.7	814.3	863.6	900.2		22.4	19.1	9.7
in. 34"	39.56	1.94	4.34	35.12	34.06	36.25	37.69	40	1	07/08/07	0.38
mm.	1004.8	49.3	110.2	892	865.1	920.8	957.3		25.4	22.2	9.7
in. 36"	41.62	2.06	4.62	37.19	36.06	38.25	39.75	44	1	07/08/07	0.38
mm.	1057.1	52.3	117.3	944.6	915.9	971.6	1009.7		25.4	22.2	9.7
in. 38"	44.25	2.12	4.88	39.12	38.12	40.25	42.12	40	1.12	1	0.38
mm.	1124	53.8	124	993.6	968.2	1022.4	1069.8		28.4	25.4	9.7
in. 40"	46.25	2.19	5.06	41.31	40.12	42.5	44.12	44	1.12	1	0.38
mm.	1174.8	55.6	128.5	1049.3	1019	1079.5	1120.6		28.4	25.4	9.7
in. 42"	48.25	2.31	5.25	43.38	42.12	44.5	46.12	48	1.12	1	0.44
mm.	1225.6	58.7	133.4	1101.9	1069.8	1130.3	1171.4		28.4	25.4	11.2
in. 44"	50.25	2.38	5.38	45.38	44.12	46.5	48.12	52	1.12	1	0.44
mm.	1276.4	60.5	136.7	1152.7	1120.6	1181.1	1222.2		28.4	25.4	11.2
in. 46"	52.81	2.44	5.69	47.44	46.12	48.62	50.56	40	1.25	1 1/8	0.44
mm.	1341.4	62	144.5	1205	1171.4	1234.9	1284.2		31.8	28.6	11.2
in. 48"	54.81	2.56	5.88	49.5	48.12	50.75	52.56	44	1.25	1 1/8	0.44
mm.	1392.2	65	149.4	1257.3	1222.2	1289.1	1335		31.8	28.6	11.2
in. 50"	56.81	2.69	6.06	51.5	50.12	52.75	54.56	48	1.25	1 1/8	0.44
mm.	1443	68.3	153.9	1308.1	1273	1339.9	1385.8		31.8	28.6	11.2
in. 52"	58.81	2.75	6.19	53.56	52.12	54.75	56.56	52	1.25	1 1/8	0.44
mm.	1493.8	69.9	157.2	1360.4	1323.8	1390.7	1436.6		31.8	28.6	11.2
in. 54"	61	2.81	6.38	55.62	54.12	56.75	58.75	56	1.25	1 1/8	0.44
mm.	1549.4	71.4	162.1	1412.7	1374.6	1441.5	1492.3		31.8	28.6	11.2
in. 56"	63	2.88	6.56	57.69	56.12	58.75	60.75	60	1.25	1 1/8	0.56
mm.	1600.2	73.2	166.6	1465.3	1425.4	1492.3	1543.1		31.8	28.6	14.2
in. 58"	65.94	2.94	6.88	59.69	58.12	60.75	63.44	48	1.38	1 1/4	0.56
mm.	1674.9	74.7	174.8	1516.1	1476.2	1543.1	1611.4		35.1	31.8	14.2
in. 60"	67.94	3	7.06	61.81	60.12	63	65.44	52	1.38	1 1/4	0.56
mm.	1725.7	76.2	179.3	1570	1527	1600.2	1662.2		35.1	31.8	14.2



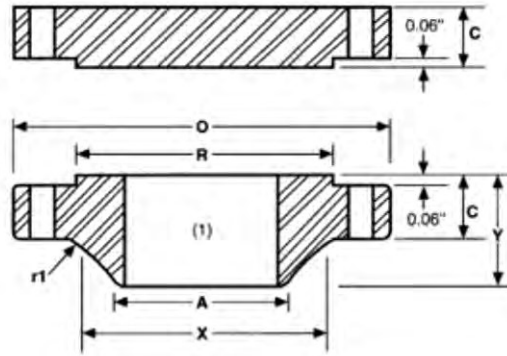

Class 300

Nom. Size	Outside diam. of flange	Thick. of flange	Length through hub	Diam. of hub	Hub diam. top	Raised face diam.	Diam. of bolt circle	No. of holes	Diam. of bolt hole	Diam. of bolt	Fillet radius min.
in. 26"	34.12	3.5	5.69	27.62	26.19	29	31.62	32	1.38	1 1/4	0.56
mm.	866.6	88.9	144.5	701.5	665.2	736.6	803.1		35.1	31.8	14.2
in. 28"	36.25	3.5	5.88	29.75	28.19	31	33.75	36	1.38	1 1/4	0.56
mm.	920.8	88.9	149.4	755.7	716	787.4	857.3		35.1	31.8	14.2
in. 30"	39	3.69	6.22	32	30.25	33.25	36.25	36	1.5	1 3/8	0.56
mm.	990.6	93.7	158	812.8	768.4	844.6	920.8		38.1	34.9	14.2
in. 32"	41.5	4.06	6.62	34	32.25	35.5	38.5	32	1.62	1 1/2	0.62
mm.	1054.1	103.1	168.1	863.6	819.2	901.7	977.9		41.1	38.1	15.7
in. 34"	43.62	4.06	6.81	36.12	34.25	37.5	40.62	36	1.62	1 1/2	0.62
mm.	1107.9	103.1	173	917.4	870	952.5	1031.7		41.1	38.1	15.7
in. 36"	46.12	4.06	7.12	38	36.25	39.75	42.88	32	1.75	1 5/8	0.62
mm.	1171.4	103.1	180.8	965.2	920.8	1009.7	1089.2		44.5	41.3	15.7
in. 38"	48.12	4.38	7.56	40	38.25	41.75	44.88	36	1.75	1 5/8	0.62
mm.	1222.2	111.3	192	1016	971.6	1060.5	1140		44.5	41.3	15.7
in. 40"	50.12	4.56	7.81	42	40.25	43.88	46.88	40	1.75	1 5/8	0.62
mm.	1273	115.8	198.4	1066.8	1022.4	1114.6	1190.8		44.5	41.3	15.7
in. 42"	52.5	4.69	8.06	44	42.31	46	49	36	1.88	1 3/4	0.62
mm.	1333.5	119.1	204.7	1117.6	1074.7	1168.4	1244.6		47.8	44.5	15.7
in. 44"	54.5	5	8.44	46.19	44.31	48	51	40	1.88	1 3/4	0.62
mm.	1384.3	127	214.4	1173.2	1125.5	1219.2	1295.4		47.8	44.5	15.7
in. 46"	57.5	5.06	8.75	48.38	46.31	50	53.75	36	2	1 7/8	0.62
mm.	1460.5	128.5	222.3	1228.9	1176.3	1270	1365.3		50.8	47.6	15.7
in. 48"	59.5	5.06	8.81	50.31	48.31	52.25	55.75	40	2	1 7/8	0.62
mm.	1511.3	128.5	223.8	1277.9	1227.1	1327.2	1416.1		50.8	47.6	15.7
in. 50"	61.5	5.44	9.25	52.38	50.31	54.25	57.75	44	2	1 7/8	0.62
mm.	1562.1	138.2	235	1330.5	1277.9	1378	1466.9		50.8	47.6	15.7
in. 52"	63.5	5.62	9.56	54.44	52.31	56.25	59.75	48	2	1 7/8	0.62
mm.	1612.9	142.7	242.8	1382.8	1328.7	1428.8	1517.7		50.8	47.6	15.7
in. 54"	65.88	5.38	9.44	56.5	54.31	58.25	62.12	48	2	1 7/8	0.62
mm.	1673.4	136.7	239.8	1435.1	1379.5	1479.6	1577.8		50.8	47.6	15.7
in. 56"	69.5	6.06	10.56	58.81	56.31	60.5	65	36	2.38	2 1/4	0.69
mm.	1765.3	153.9	268.2	1493.8	1430.3	1536.7	1651		60.5	57.2	17.5
in. 58"	71.94	6.06	10.81	60.94	58.31	62.75	67.44	40	2.38	2 1/4	0.69
mm.	1827.3	153.9	274.6	1547.9	1481.1	1593.9	1713		60.5	57.2	17.5
in. 60"	73.94	5.94	10.69	62.94	60.31	65	69.44	40	2.38	2 1/4	0.69
mm.	1878.1	150.9	271.5	1598.7	1531.9	1651	1763.8		60.5	57.2	17.5

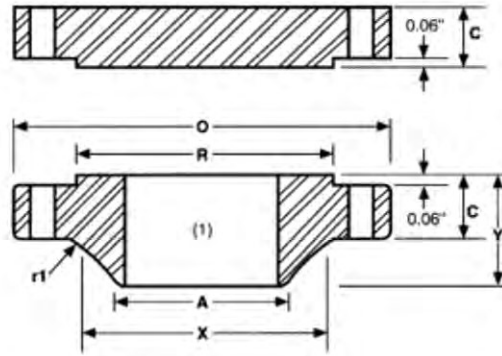

Class 400

Nom. Size		Outside diam. of flange	Thick. of flange	Length through hub	Diam. of hub	Hub diam. top	Raised face diam.	Diam. of bolt circle	No. of holes	Diam. of bolt hole	Diam. of bolt	Fillet radius min.
in.	26"	33.5	3.5	5.88	27.12	26	28	30.75	28	1.5	1 3/8	0.44
mm.		850.9	88.9	149.4	688.8	660.4	711.2	781.1		38.1	34.9	11.2
in.	28"	36	3.75	6.25	29.12	28	30	33	24	1.62	1 1/2	0.5
mm.		914.4	95.3	158.8	739.6	711.2	762	838.2		41.1	38.1	12.7
in.	30"	38.25	4	6.69	31.25	30	32.25	35.25	28	1.62	1 1/2	0.5
mm.		971.6	101.6	169.9	793.8	762	819.2	895.4		41.1	38.1	12.7
in.	32"	40.75	4.25	7.06	33.25	32	34.38	37.5	28	1.75	1 5/8	0.5
mm.		1035.1	108	179.3	844.6	812.8	873.3	952.5		44.5	41.3	12.7
in.	34"	42.75	4.38	7.38	35.38	34	36.5	39.5	32	1.75	1 5/8	0.56
mm.		1085.9	111.3	187.5	898.7	863.6	927.1	1003.3		44.5	41.3	14.2
in.	36"	45.5	4.69	7.88	37.5	36	38.62	42	28	1.88	1 3/4	0.56
mm.		1155.7	119.1	200.2	952.5	914.4	980.9	1066.8		47.8	44.5	14.2

Class 600

Nom. Size		Outside diam. of flange	Thick. of flange	Length through hub	Diam. of hub	Hub diam. top	Raised face diam.	Diam. of bolt circle	No. of holes	Diam. of bolt hole	Diam. of bolt	Fillet radius min.
in.	26"	35	4.38	7.12	27.5	26	28.62	31.75	28	1.75	1 5/8	0.5
mm.		889	111.3	180.8	698.5	660.4	726.9	806.5		44.5	41.3	12.7
in.	28"	37.5	4.56	7.5	29.62	28	30.88	34	28	1.88	1 3/4	0.5
mm.		952.5	115.8	190.5	752.3	711.2	784.4	863.6		47.8	44.5	12.7
in.	30"	40.25	4.94	8.06	31.75	30	33.12	36.5	28	2	1 7/8	0.5
mm.		1022.4	125.5	204.7	806.5	762	841.2	927.1		50.8	47.6	12.7
in.	32"	42.75	5.12	8.5	33.88	32	35.25	38.75	28	2.12	2	0.5
mm.		1085.9	130	215.9	860.6	812.8	895.4	984.3		53.8	50.8	12.7
in.	34"	45.75	5.56	9.19	36	34	37.5	41.5	24	2.38	2 1/4	0.56
mm.		1162.1	141.2	233.4	914.4	863.6	952.5	1054.1		60.5	57.2	14.2
in.	36"	47.75	5.76	9.56	38.12	36	39.75	43.5	28	2.38	2 1/4	0.56
mm.		1212.9	146.3	242.8	968.2	914.4	1009.7	1104.9		60.5	57.2	14.2

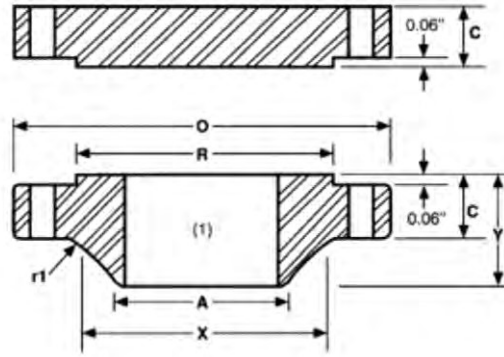

Class 900

Nom. Size	Outside diam. of flange	Thick. of flange	Length through hub	Diam. of hub	Hub diam. top	Raised face diam.	Diam. of bolt circle	No. of holes	Diam. of bolt hole	Diam. of bolt	Fillet radius min.
in. 26"	40.25	5.31	10.19	29.25	26	30	35.5	20	2.62	2 1/2	0.44
mm.	1022.4	134.9	258.8	743	660.4	762	901.7		66.5	63.5	11.2
in. 28"	43.5	5.81	10.88	31.38	28	32.25	38.25	20	2.88	2 3/4	0.5
mm.	1104.9	147.6	276.4	797.1	711.2	819.2	971.6		73.2	69.9	12.7
in. 30"	46.5	6.12	11.38	33.5	30	34.5	40.75	20	3.12	3	0.5
mm.	1181.1	155.4	289.1	850.9	762	876.3	1035.1		79.2	76.2	12.7
in. 32"	48.75	6.31	11.94	35.75	32	36.5	43	20	3.12	3	0.5
mm.	1238.3	160.3	303.3	908.1	812.8	927.1	1092.2		79.2	76.2	12.7
in. 34"	51.75	6.75	12.56	37.88	34	39	45.5	20	3.38	3 1/4	0.56
mm.	1314.5	171.5	319	962.2	863.6	990.6	1155.7		85.9	82.6	14.2
in. 36"	53	6.81	12.81	40	36	40.5	47.25	24	3.12	3	0.56
mm.	1346.2	173	325.4	1016	914.4	1028.7	1200.2		79.2	76.2	14.2

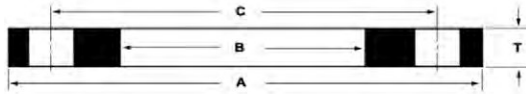

- All dimensions are in inches.
- Pressure rating at atmospheric temperature is 86 psi.

Nom. Size	Outside Diam. (A)	Thickness (T)	Inside Diam. (B)	Approx. Weight (lbs)	Number of Bolt Holes	Diam. of Bolt Holes	Diam. of Bolt Circle (C)
4	9.00	0.625	4.57	8	8	0.750	7.50
5	10.00	0.625	5.66	9	8	0.875	8.50
6	11.00	0.688	6.72	11	8	0.875	9.50
8	13.50	0.688	8.72	16	8	0.875	11.75
10	16.00	0.688	10.88	20	12	1.000	14.25
12	19.00	0.688	12.88	30	12	1.000	17.00
14	21.00	0.688	14.19	36	12	1.125	18.75
16	23.50	0.688	16.19	43	16	1.125	21.25
18	25.00	0.688	18.19	43	16	1.250	22.75
20	27.50	0.688	20.19	51	20	1.250	25.00
22	29.50	0.750	22.19	60	20	1.375	27.25
24	32.00	0.750	24.19	70	20	1.375	29.50
26	34.25	0.812	26.19	84	24	1.375	31.75
28	36.50	0.875	28.19	99	28	1.375	34.00
30	38.75	0.875	30.19	110	28	1.375	36.00
32	41.75	0.938	32.19	139	28	1.625	38.50
34	43.75	0.938	34.19	149	32	1.625	40.50
36	46.00	1.000	36.19	169	32	1.625	42.75
38	48.75	1.000	38.19	195	32	1.625	45.25
40	50.75	1.000	40.19	203	36	1.625	47.25
42	53.00	1.125	42.19	246	36	1.625	49.50
44	55.25	1.125	44.19	262	40	1.625	51.75
46	57.25	1.125	46.19	274	40	1.625	53.75
48	59.50	1.250	48.19	323	44	1.625	56.00
50	61.75	1.250	50.19	334	44	1.875	58.25
52	64.00	1.250	52.19	356	44	1.875	60.50
54	66.25	1.375	54.19	418	44	1.875	62.75
60	73.00	1.500	60.19	535	52	1.875	69.25
66	80.00	1.625	66.19	699	52	1.875	76.00
72	86.50	1.750	72.19	844	60	1.875	82.50
78	93.00	2.000	78.19	1052	64	2.125	89.00
84	99.75	2.000	84.19	1205	64	2.125	95.50
90	106.50	2.250	90.19	1478	68	2.438	102.00
96	113.25	2.250	96.19	1670	68	2.438	108.50
102	120.00	2.500	102.19	2013	72	2.688	114.50
108	126.75	2.500	108.19	2249	72	2.688	120.75
114	133.50	2.750	114.19	2658	76	2.938	126.75
120	140.25	2.750	120.19	2943	76	2.938	132.75
126	147.00	3.000	126.19	3423	80	3.188	139.25
132	153.75	3.000	132.19	3761	80	3.188	145.75
138	160.50	3.250	138.19	4317	84	3.438	152.00
144	167.25	3.250	144.19	4711	84	3.438	158.25

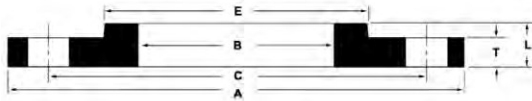

- All dimensions are in inches.
- Pressure rating at atmospheric temperature is 175 psi for sizes 12" and under and 150 psi for sizes 14" and up.

Nom. Size	Outside Diam. (A)	Thickness (T)	Overall Thickness (L)	Hub Diam. (E)	Inside Diam. (B)	Approx. Weight (lbs)	Number of Bolt Holes	Diam. of Bolt Holes	Diam. of Bolt Circle (C)
4	9.00	0.500	0.875	5.312	4.57	7	8	0.750	7.50
5	10.00	0.562	1.250	6.312	5.66	8	8	0.875	8.50
6	11.00	0.562	1.250	7.562	6.72	13	8	0.875	9.50
8	13.50	0.562	1.250	9.688	8.72	18	8	0.875	11.75
10	16.00	0.688	1.250	12.000	10.88	26	12	1.000	14.25
12	19.00	0.688	1.250	14.375	12.88	42	12	1.000	17.00
14	21.00	0.750	1.250	15.750	14.19	44	12	1.125	18.75
16	23.50	0.750	1.250	18.000	16.19	58	16	1.125	21.25
18	25.00	0.750	1.250	19.875	18.19	59	16	1.250	22.75
20	27.50	0.750	1.250	22.000	20.19	69	20	1.250	25.00
22	29.50	1.000	1.750	24.250	22.19	76	20	1.375	27.25
24	32.00	1.000	1.750	26.125	24.19	115	20	1.375	29.50
26	34.25	1.000	1.750	28.500	26.19	125	24	1.375	31.75
28	36.50	1.000	1.750	30.500	28.19	140	28	1.375	34.00
30	38.75	1.000	1.750	32.500	30.19	150	28	1.375	36.00
32	41.75	1.125	1.750	34.750	32.19	205	28	1.625	38.50
34	43.75	1.125	1.750	36.750	34.19	215	32	1.625	40.50
36	46.00	1.125	1.750	38.750	36.19	235	32	1.625	42.75
38	48.75	1.125	1.750	40.750	38.19	265	32	1.625	45.25
40	50.75	1.125	1.750	43.000	40.19	280	36	1.625	47.25
42	53.00	1.250	1.750	45.000	42.19	330	36	1.625	49.50
44	55.25	1.250	2.250	47.000	44.19	350	40	1.625	51.75
46	57.25	1.250	2.250	49.000	46.19	365	40	1.625	53.75
48	59.50	1.375	2.500	51.000	48.19	425	44	1.625	56.00
50	61.75	1.375	2.500	53.000	50.19	450	44	1.875	58.25
52	64.00	1.375	2.500	55.000	52.19	475	44	1.875	60.50
54	66.25	1.375	2.500	57.000	54.19	500	44	1.875	62.75
60	73.00	1.500	2.750	63.000	60.19	640	52	1.875	69.25
66	80.00	1.500	2.750	69.000	66.19	750	52	1.875	76.00
72	86.50	1.500	2.750	75.000	72.19	850	60	1.875	82.50
78	93.00	1.750	3.000	81.250	78.19	1200	64	2.125	89.00
84	99.75	1.750	3.000	87.500	84.19	1250	64	2.125	95.50
90	106.50	2.000	3.250	93.750	90.19	1650	68	2.438	102.00
96	113.25	2.000	3.250	100.000	96.19	1750	68	2.438	108.50

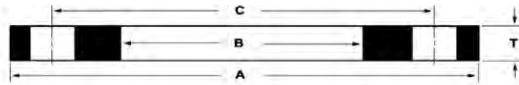

- All dimensions are in inches.
- Pressure rating at atmospheric temperature is 175 psi for sizes 12" and under and 150 psi for sizes 14" and up.

Nom. Size	Outside Diam. (A)	Thickness (T)	Inside Diam. (B)	Approx. Weight (lbs)	Number of Bolt Holes	Diam. of Bolt Holes	Diam. of Bolt Circle (C)
4	9	0.625	4.57	8	8	0.75	7.50
5	10	0.625	5.66	9	8	0.875	8.50
6	11	0.688	6.72	11	8	0.875	9.50
8	13.5	0.688	8.72	15	8	0.875	11.75
10	16	0.688	10.88	19	12	1	14.25
12	19	0.812	12.88	33	12	1	17.00
14	21	0.938	14.19	47	12	1.125	18.75
16	23.5	1	16.19	60	16	1.125	21.25
18	25	1.062	18.19	68	16	1.25	22.75
20	27.5	1.125	20.19	79	20	1.25	25.00
22	29.5	1.188	22.19	90	20	1.375	27.25
24	32	1.25	24.19	112	20	1.375	29.50
26	34.25	1.312	26.19	129	24	1.375	31.75
28	36.5	1.312	28.19	141	28	1.375	34.00
30	38.75	1.375	30.19	172	28	1.375	36.00
32	41.75	1.5	32.19	211	28	1.625	38.50
34	43.75	1.5	34.19	220	32	1.625	40.50
36	46	1.625	36.19	261	32	1.625	42.75
38	48.75	1.625	38.19	301	32	1.625	45.25
40	50.75	1.625	40.19	313	36	1.625	47.25
42	53	1.75	42.19	364	36	1.625	49.50
44	55.25	1.75	44.19	387	40	1.625	51.75
46	57.25	1.75	46.19	404	40	1.625	53.75
48	59.5	1.875	48.19	460	44	1.625	56.00
50	61.75	2	50.19	507	44	1.875	58.25
52	64	2	52.19	542	44	1.875	60.50
54	66.25	2.125	54.19	614	44	1.875	62.75
60	73	2.25	60.19	763	52	1.875	69.25
66	80	2.5	66.19	1021	52	1.875	76.00
72	86.5	2.625	72.19	1203	60	1.875	82.50
78	93	2.75	78.19	1374	64	2.125	89.00
84	99.75	2.875	84.19	1646	64	2.125	95.50
90	106.5	3	90.19	1872	68	2.438	102.00
96	113.25	3.25	96.19	2292	68	2.438	108.50
102	120	3.25	102.2	2486	72	2.688	114.50
108	126.75	3.375	108.2	2884	72	2.688	120.75
114	133.5	3.5	114.2	3214	76	2.938	126.75
120	140.25	3.5	120.2	3558	76	2.938	132.75
126	147	3.75	126.2	4065	80	3.188	139.25
132	153.75	3.875	132.2	4614	80	3.188	145.75
138	160.5	4	138.2	5047	84	3.438	152.00
144	167.25	4.125	144.2	5681	84	3.438	158.25

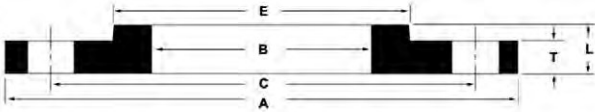

- All dimensions are in inches.
- The pressure rating at atmospheric temperature is 175 psi for 6" - 12" and 150 psi for 14" - 96".

Nom. Size	Outside Diam. (A)	Thickness (T)	Overall Thickness (L)	Hub Diam. (E)	Inside Diam. (B)	Approx. Weight (lbs)	Number of Bolt Holes	Diam. of Bolt Holes	Diam. of Bolt Circle (C)
4	9	0.5	0.875	5.312	4.57	7	8	0.750	7.50
5	10	0.562	1.25	6.312	5.66	8	8	0.875	8.50
6	11	0.562	1.25	7.562	6.72	13	8	0.875	9.50
8	13.5	0.562	1.25	9.688	8.72	18	8	0.875	11.75
10	16	0.688	1.25	12.000	10.88	26	12	1.000	14.25
12	19	0.688	1.25	14.375	12.88	42	12	1.000	17.00
14	21	0.75	1.25	15.750	14.19	44	12	1.125	18.75
16	23.5	0.75	1.25	18.000	16.19	58	16	1.125	21.25
18	25	0.75	1.25	19.875	18.19	59	16	1.250	22.75
20	27.5	0.75	1.25	22.000	20.19	69	20	1.250	25.00
22	29.5	1	1.75	24.250	22.19	76	20	1.375	27.25
24	32	1	1.75	26.125	24.19	115	20	1.375	29.50
26	34.25	1	1.75	28.500	26.19	125	24	1.375	31.75
28	36.5	1	1.75	30.500	28.19	140	28	1.375	34.00
30	38.75	1	1.75	32.500	30.19	150	28	1.375	36.00
32	41.75	1.125	1.75	34.750	32.19	205	28	1.625	38.50
34	43.75	1.125	1.75	36.750	34.19	215	32	1.625	40.50
36	46	1.125	1.75	38.750	36.19	235	32	1.625	42.75
38	48.75	1.125	1.75	40.750	38.19	265	32	1.625	45.25
40	50.75	1.125	1.75	43.000	40.19	280	36	1.625	47.25
42	53	1.25	1.75	45.000	42.19	330	36	1.625	49.50
44	55.25	1.25	2.25	47.000	44.19	350	40	1.625	51.75
46	57.25	1.25	2.25	49.000	46.19	365	40	1.625	53.75
48	59.5	1.375	2.5	51.000	48.19	425	44	1.625	56.00
50	61.75	1.375	2.5	53.000	50.19	450	44	1.875	58.25
52	64	1.375	2.5	55.000	52.19	475	44	1.875	60.50
54	66.25	1.375	2.5	57.000	54.19	500	44	1.875	62.75
60	73	1.5	2.75	63.000	60.19	640	52	1.875	69.25
66	80	1.5	2.75	69.000	66.19	750	52	1.875	76.00
72	86.5	1.5	2.75	75.000	72.19	850	60	1.875	82.50
78	93	1.75	3	81.250	78.19	1200	64	2.125	89.00
84	99.75	1.75	3	87.500	84.19	1250	64	2.125	95.50
90	106.5	2	3.25	93.750	90.19	1650	68	2.438	102.00
96	113.25	2	3.25	100.000	96.19	1750	68	2.438	108.50



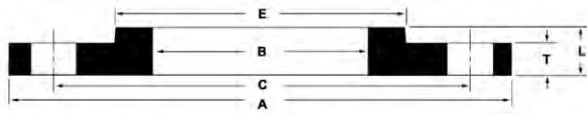

- All dimensions are in inches.
- Pressure rating at atmospheric temperature is 275 psi.

Nom. Size	Outside Diam. (A)	Thickness (T)	Overall Thickness (L)	Hub Diam. (E)	Inside Diam. (B)	Approx. Weight (lbs)	Number of Bolt Holes	Diam. of Bolt Holes	Diam. of Bolt Circle (C)
4	9	0.938	1.312	5.312	4.57	13	8	0.750	7.50
5	10	0.938	1.438	6.438	5.66	15	8	0.875	8.50
6	11	1	1.562	7.562	6.72	19	8	0.875	9.50
8	13.5	1.125	1.75	9.688	8.72	30	8	0.875	11.75
10	16	1.188	1.938	12.000	10.88	43	12	1.000	14.25
12	19	1.25	2.188	14.375	12.88	64	12	1.000	17.00
14	21	1.375	2.25	15.750	14.19	85	12	1.125	18.75
16	23.5	1.438	2.5	18.000	16.19	98	16	1.125	21.25
18	25	1.562	2.688	19.875	18.19	120	16	1.250	22.75
20	27.5	1.688	2.875	22.000	20.19	155	20	1.250	25.00
22	29.5	1.812	3.125	24.000	22.19	190	20	1.375	27.25
24	32	1.875	3.25	26.125	24.19	210	20	1.375	29.50
26	34.25	2	3.375	28.500	26.19	235	24	1.375	31.75
28	36.5	2.062	3.438	30.750	28.19	270	28	1.375	34.00
30	38.75	2.125	3.5	32.750	30.19	305	28	1.375	36.00
32	41.75	2.25	3.625	35.000	32.19	375	28	1.625	38.50
34	43.75	2.312	3.688	37.000	34.19	400	32	1.625	40.50
36	46	2.375	3.75	39.250	36.19	450	32	1.625	42.75
38	48.75	2.375	3.75	41.750	38.19	530	32	1.625	45.25
40	50.75	2.5	3.875	43.750	40.19	570	36	1.625	47.25
42	53	2.625	4	46.000	42.19	650	36	1.625	49.50
44	55.25	2.625	4	48.000	44.19	690	40	1.625	51.75
46	57.25	2.688	4.062	50.000	46.19	730	40	1.625	53.75
48	59.5	2.75	4.125	52.250	48.19	800	44	1.625	56.00
50	61.75	2.75	4.125	54.250	50.19	830	44	1.875	58.25
52	64	2.875	4.25	56.500	52.19	920	44	1.875	60.50
54	66.25	3	4.375	58.750	54.19	1025	44	1.875	62.75
60	73	3.125	4.5	65.250	60.19	1250	52	1.875	69.25
66	80	3.375	4.875	71.500	66.19	1625	52	1.875	76.00
72	86.5	3.5	5	78.500	72.19	1925	60	1.875	82.50
78	93	3.875	5.375	84.500	78.19	2525	64	2.125	89.00
84	99.75	3.875	5.375	90.500	84.19	2600	64	2.125	95.50
90	106.5	4.25	5.75	96.750	90.19	3150	68	2.438	102.00
96	113.25	4.25	5.75	102.750	96.19	3275	68	2.438	108.50



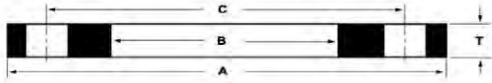

- All dimensions are in inches.
- Pressure rating at atmospheric temperature is 175 psi for sizes 12" and under and 150 psi for sizes 14" and up.

Nom. Size	Outside Diam. (A)	Thickness (T)	Inside Diam. (B)	Approx. Weight (lbs)	Number of Bolt Holes	Diam. of Bolt Holes	Diam. of Bolt Circle (C)
4	9	1.125	4.57	14	8	0.75	7.5
5	10	1.188	5.66	16	8	0.875	8.5
6	11	1.313	6.72	22	8	0.875	9.5
8	13.5	1.5	8.72	33	8	0.875	11.75
10	16	1.563	10.88	47	12	1	14.25
12	19	1.75	12.88	71	12	1	17
14	21	1.875	14.19	94	12	1.125	18.75
16	23.5	2	16.19	120	16	1.125	21.25
18	25	2.125	18.19	127	16	1.25	22.75
20	27.5	2.375	20.19	168	20	1.25	25
22	29.5	2.5	22.19	189	20	1.375	27.25
24	32	2.625	24.19	234	20	1.375	29.5
26	34.25	2.75	26.19	270	24	1.375	31.75
28	36.5	2.75	28.19	297	28	1.375	34
30	38.75	2.875	30.19	344	28	1.375	36
32	41.75	3	32.19	422	28	1.625	38.5
34	43.75	3	34.19	460	32	1.625	40.5
36	46	3.125	36.19	502	32	1.625	42.75
38	48.75	3.125	38.19	580	32	1.625	45.25
40	50.75	3.25	40.19	626	36	1.625	47.25
42	53	3.375	42.19	701	36	1.625	49.5
44	55.25	3.375	44.19	747	40	1.625	51.75
46	57.25	3.438	46.19	794	40	1.625	53.75
48	59.5	3.5	48.19	858	44	1.625	56
50	61.75	3.5	50.19	887	44	1.875	58.25
52	64	3.625	52.19	982	44	1.875	60.5
54	66.25	3.75	54.19	1083	44	1.875	62.75
60	73	3.875	60.19	1313	52	1.875	69.25
66	80	4.25	66.19	1736	52	1.875	76
72	86.5	4.375	72.19	2005	60	1.875	82.5
78	93	4.75	78.19	2374	64	2.125	89
84	99.75	4.75	84.19	2719	64	2.125	95.5
90	106.5	5.125	90.19	3197	68	2.438	102
96	113.25	5.125	96.19	3614	68	2.438	108.5
102	120	5.5	102.2	4206	72	2.688	114.5
108	126.75	5.5	108.2	4700	72	2.688	120.75
114	133.5	5.875	114.2	5395	76	2.938	126.75
120	140.25	5.875	120.2	5972	76	2.938	132.75
126	147	6.25	126.2	6776	80	3.188	139.25
132	153.75	6.25	132.2	7443	80	3.188	145.75
138	160.5	6.75	138.2	8517	84	3.438	152
144	167.25	6.75	144.2	9295	84	3.438	158.25

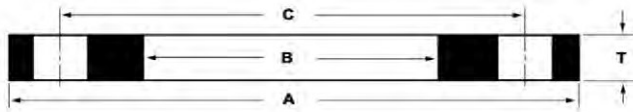

- All dimensions are in inches.
- Pressure rating at atmospheric temperature is 300 psi.

Nom. Size	Outside Diam. (A)	Thickness (T)	Inside Diam. (B)	Approx. Weight (lbs)	Number of Bolt Holes	Diam. of Bolt Holes	Diam. of Bolt Circle (C)
4	10	1.13	4.57	18	8	0.875	7.88
5	11	1.21	5.66	22	8	0.875	9.25
6	12.5	1.31	6.73	30	12	0.875	10.62
8	15	1.31	8.73	40	12	1	13
10	17.5	1.5	10.88	56	16	1.125	15.25
12	20.5	1.63	12.88	83	16	1.25	17.75
14	23	1.94	14.19	128	20	1.25	20.25
16	25.5	2.14	16.19	167	20	1.375	22.5
18	28	2.25	18.19	204	24	1.375	24.75
20	30.5	2.33	20.19	247	24	1.375	27
22	33	2.5	22.19	307	24	1.375	29.25
24	36	2.69	24.19	388	24	1.625	32
26	38.25	3	26.25	451	28	1.875	34.5
28	40.75	3.13	28.25	532	28	1.875	37
30	43	3.15	30.25	586	28	1.875	39.25
32	45.25	3.25	32.25	657	28	1.875	41.5
34	47.5	3.38	34.25	741	28	1.875	43.5
36	50	3.46	36.25	802	32	2.125	46
38	52.25	3.5	38.25	874	32	2.125	48
40	54.25	3.63	40.25	937	36	2.125	50.25
42	57	3.81	42.25	1103	36	2.125	52.75
44	59.25	4	44.25	1237	36	2.125	55
46	61.5	4.13	46.25	1344	40	2.125	57.25
48	65	4.5	48.25	1718	40	2.125	60.75

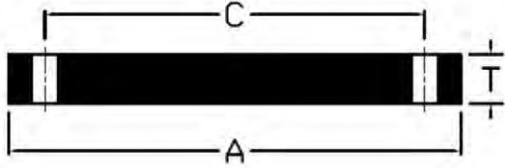

- All dimensions are in inches.
- Blind flanges shall be machined with center island to match the mating flange.

Nom. Size	Outside Diam. (A)	Thickness (T)	Approx. Weight (lbs)	Number of Bolt Holes	Diam. of Bolt Holes	Diam. of Bolt Circle (C)
4	9	0.625	14	8	0.75	7.5
5	10	0.625	17	8	0.875	8.5
6	11	0.688	22	8	0.875	9.5
8	13.5	0.688	33	8	0.875	11.75
10	16	0.688	46	12	1	14.25
12	19	0.719	68	12	1	17
14	21	0.791	90	12	1.125	18.75
16	23.5	0.892	125	16	1.125	21.25
18	25	0.95	149	16	1.25	22.75
20	27.5	1.04	207	20	1.25	25
22	29.5	1.132	255	20	1.375	27.25
24	32	1.216	320	20	1.375	29.5
26	34.25	1.307	390	24	1.375	31.75
28	36.5	1.398	470	28	1.375	34
30	38.75	1.477	546	28	1.375	36
32	41.75	1.581	686	28	1.625	38.5
34	43.75	1.661	787	32	1.625	40.5
36	46	1.751	913	32	1.625	42.75
38	48.75	1.853	1079	32	1.625	45.25
40	50.75	1.933	1215	36	1.625	47.25
42	53	2.023	1382	36	1.625	49.5
44	55.25	2.114	1563	40	1.625	51.75
46	57.25	2.194	1737	40	1.625	53.75
48	59.5	2.285	1948	44	1.625	56
50	61.75	2.377	2176	44	1.875	58.25
52	64	2.468	2420	44	1.875	60.5
54	66.25	2.559	2682	44	1.875	62.75
60	73	2.82	3566	52	1.875	69.25
66	80	3.092	4670	52	1.875	76
72	86.5	3.353	5894	60	1.875	82.5

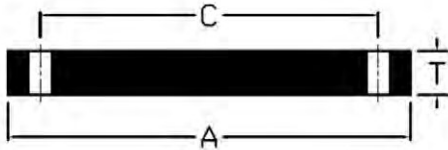

- All dimensions are in inches.
- Blind flanges shall be machined with center island to match the mating flange.

Nom. Size	Outside Diam. (A)	Thickness (T)	Approx. Weight (lbs)	Number of Bolt Holes	Diam. of Bolt Holes	Diam. of Bolt Circle (C)
4	9	0.625	14	8	0.75	7.5
5	10	0.65	17	8	0.875	8.5
6	11	0.693	22	8	0.875	9.5
8	13.5	0.812	38	8	0.875	11.75
10	16	0.953	61	12	1	14.25
12	19	1.117	100	12	1	17
14	21	1.133	123	12	1.125	18.75
16	23.5	1.265	171	16	1.125	21.25
18	25	1.331	202	16	1.25	22.75
20	27.5	1.448	275	20	1.25	25
22	29.5	1.568	340	20	1.375	27.25
24	32	1.661	421	20	1.375	29.5
26	34.25	1.786	515	24	1.375	31.75
28	36.5	1.906	621	28	1.375	34
30	38.75	2.008	734	28	1.375	36
32	41.75	2.15	907	28	1.625	38.5
34	43.75	2.25	1039	32	1.625	40.5
36	46	2.37	1204	32	1.625	42.75
38	48.75	2.506	1424	32	1.625	45.25
40	50.75	2.609	1603	36	1.625	47.25
42	53	2.729	1823	36	1.625	49.5
44	55.25	2.849	2062	40	1.625	51.75
46	57.25	2.952	2290	40	1.625	53.75
48	59.5	3.072	2568	44	1.625	56
50	61.75	3.196	2871	44	1.875	58.25
52	64	3.315	3192	44	1.875	60.5
54	66.25	3.435	3538	44	1.875	62.75
60	73	3.779	4703	52	1.875	69.25
66	80	4.136	6157	52	1.875	76
72	86.5	4.48	7770	60	1.875	82.5

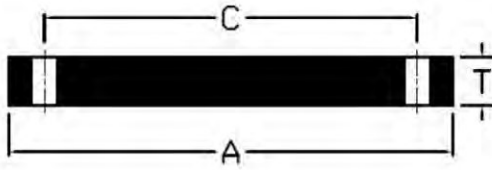

- All dimensions are in inches.
- Blind flanges shall be machined with center island to match the mating flange.

Nom. Size	Outside Diam. (A)	Thickness (T)	Approx. Weight (lbs)	Number of Bolt Holes	Diam. of Bolt Holes	Diam. of Bolt Circle (C)
4	9	1.125	23	8	0.75	7.5
5	10	1.188	29	8	0.875	8.5
6	11	1.313	39	8	0.875	9.5
8	13.5	1.5	66	8	0.875	11.75
10	16	1.563	96	12	1	14.25
12	19	1.75	151	12	1	17
14	21	1.875	196	12	1.125	18.75
16	23.5	2	261	16	1.125	21.25
18	25	2.125	313	16	1.25	22.75
20	27.5	2.375	431	20	1.25	25
22	29.5	2.5	520	20	1.375	27.25
24	32	2.625	641	20	1.375	29.5
26	34.25	2.75	767	24	1.375	31.75
28	36.5	2.75	871	28	1.375	34
30	38.75	2.875	1023	28	1.375	36
32	41.75	3	1236	28	1.625	38.5
34	43.75	3.05	1379	32	1.625	40.5
36	46	3.209	1599	32	1.625	42.75
38	48.75	3.394	1894	32	1.625	45.25
40	50.75	3.533	2132	36	1.625	47.25
42	53	3.695	2427	36	1.625	49.5
44	55.25	3.857	2747	40	1.625	51.75
46	57.25	3.997	3052	40	1.625	53.75
48	59.5	4.159	3424	44	1.625	56
50	61.75	4.327	3830	44	1.875	58.25
52	64	4.489	4262	44	1.875	60.5
54	66.25	4.651	4725	44	1.875	62.75
60	73	5.116	6288	52	1.875	69.25
66	80	5.601	8243	52	1.875	76
72	86.5	6.066	10411	60	1.875	82.5

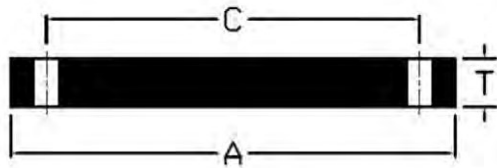

- All dimensions are in inches.
- Blind flanges shall be machined with center island to match the mating flange.

Nom. Size	Outside Diam. (A)	Thickness (T)	Approx. Weight (lbs)	Number of Bolt Holes	Diam. of Bolt Holes	Diam. of Bolt Circle (C)
4	10	1.13	28	8	0.875	7.88
5	11	1.21	36	8	0.875	9.25
6	12.5	1.31	50	12	0.875	10.62
8	15	1.31	72	12	1	13
10	17.5	1.5	111	16	1.125	15.25
12	20.5	1.63	164	16	1.25	17.75
14	23	1.94	243	20	1.25	20.25
16	25.5	2.14	328	20	1.375	22.5
18	28	2.25	414	24	1.375	24.75
20	30.5	2.33	521	24	1.375	27
22	33	2.5	651	24	1.375	29.25
24	36	2.69	830	24	1.625	32
26	38.25	3	1038	28	1.875	34.5
28	40.75	3.13	1226	28	1.875	37
30	43	3.166	1380	28	1.875	39.25
32	45.25	3.332	1603	28	1.875	41.5
34	47.5	3.475	1839	28	1.875	43.5
36	50	3.671	2146	32	2.125	46
38	52.25	3.815	2431	32	2.125	48
40	54.25	3.982	2730	36	2.125	50.25
42	57	4.171	3151	36	2.125	52.75
44	59.25	4.338	3535	36	2.125	55
46	61.5	4.505	3949	40	2.125	57.25
48	65	4.781	4671	40	2.125	60.75

A large, empty rectangular box with a thin black border, occupying the majority of the page. It is intended for taking notes.



# Technical





## BUTT WELDING FITTINGS

The tolerances shown are in accordance with the dimensional tolerances approved by the American National Standards Institute (ANSI B16.9) for all carbon and alloy

fittings except Short Radius Elbows and Returns. These are governed by ANSI B16.28.

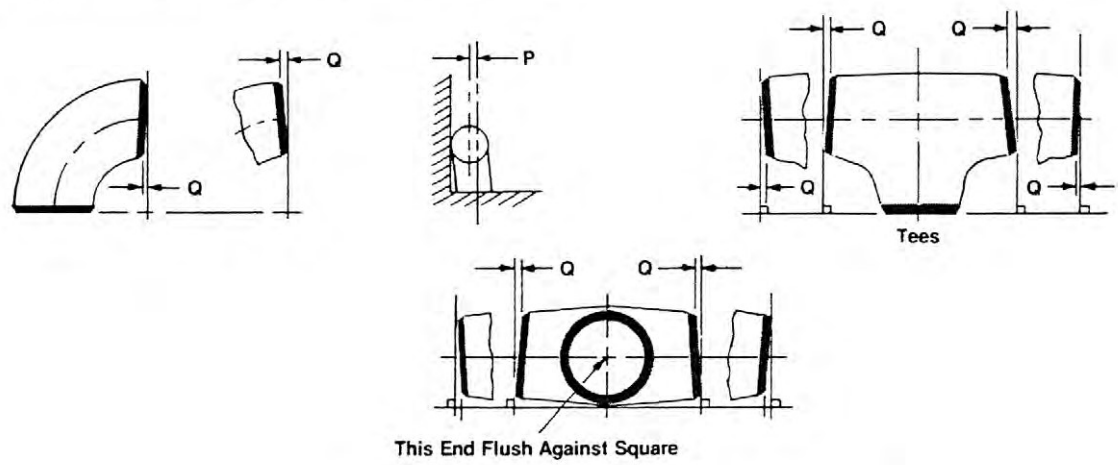

All Fittings				90 Deg. and 45 Deg. Elbows and Tees	Reducers and Lap Joint Stub Ends	Caps
Nominal Pipe Size (NPS)	Outside (1) Diameter at Bevel D	Inside (2) Diameter at End	Wall (2) Thickness t	Center-to-End Dimension A, B, C, M	Overall Length F, H	Overall Length E
½ to 2½	+0.06 -0.03	±0.03	Not less than 87.5% of nominal thickness	±0.06	±0.06	±0.12
3 to 3½	±0.06	±0.06		±0.06	±0.06	±0.12
4	±0.06	±0.06		±0.06	±0.06	±0.12
5 to 8	+0.09 -0.06	±0.06		±0.06	±0.06	±0.25
10 to 18	+0.16 -0.12	±0.12		±0.09	±0.09	±0.25
20 to 24	+0.25 -0.19	±0.19		±0.09	±0.09	±0.25
26 to 30	+0.25 -0.19	±0.19		±0.12	±0.19	±0.38
32 to 48	+0.25 -0.19	±0.19		±0.19	±0.19	±0.38

Nominal Pipe Size	Angularity Tol.	
	Off Angle Q	Off Plane P
½ to 4	0.03	0.06
5 to 8	0.06	0.12
10 to 12	0.09	0.19
14 to 16	0.09	0.25
18 to 24	0.12	0.38
26 to 30	0.19	0.38
32 to 42	0.19	0.50
44 to 48	0.19	0.75

All dimensions are in inches.  
 (1) Out-of-round is the sum of absolute values of plus and minus tolerance.  
 (2) The inside diameter at ends and the nominal wall thicknesses are to be specified by the purchaser.

## Methods of Attachment for Standard Types of Flanges

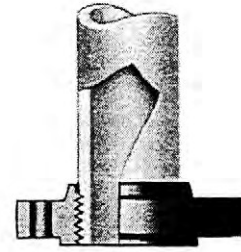

### THREADED FLANGES

Threaded Flanges are, of course, attached by screwing to threaded pipe ends. The clean, sharp threads and great precision of our Threaded Flanges assure the greatest possible ease in making up strong, tight joints.

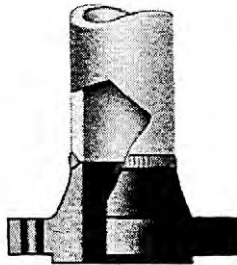

### WELDING NECK FLANGES

This type of flange is attached by butt welding to the adjoining pipe or shell. The weld may be made either manually or automatically with or without a backing strip. Sound welds are readily obtained with any recognized welding procedure.

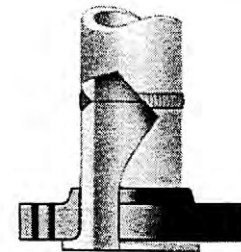

### LAP JOINT FLANGES

Lap Joint Flanges are most frequently used with Lap Joint Stub Ends, although in some cases the lap is formed on the pipe end. Since they are free to rotate or swivel, there is no problem of bolt hole alignment. Such joints may be readily broken for inspection, cleaning, etc. The radius at the ID of the flange face accommodates that at the back of the lap, thus permitting more uniform application of loading.

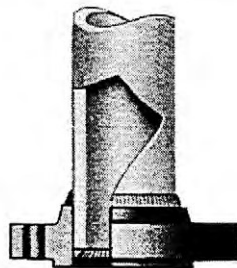

### SLIP-ON FLANGES

Although recommended practice in attaching Slip-On type Flanges is to weld both at the flange hub and the pipe end, for mild service conditions only one is sometimes employed. In this case the weld is normally made at the pipe end.

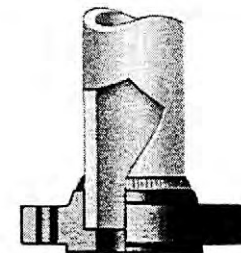

### SOCKET WELDING FLANGES

In attaching Socket Welding Flanges, the pipe end is inserted into the socket and then welded at the flange hub. An inside weld at the pipe end is frequently made for greater strength or, with grinding, to provide a smooth bore without pockets or recesses.

## threaded, lap joint, slip-on and blind flanges

### ANSI B16.5

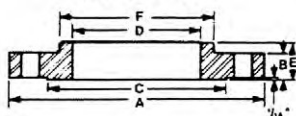

Outside Diameter (A)	When O. D. is 24" or less	$\pm \frac{1}{16}''^{(1)}$	Outside Dia. of Hub (F)	12" and Smaller	$+\frac{3}{32}''^{(1)} - \frac{1}{16}''^{(1)}$
	When O. D. is over 24"	$\pm \frac{1}{8}''^{(1)}$		Over 12"	$\pm \frac{1}{8}''^{(1)}$
Inside Diameter (D)	Threaded	Within limits on boring gauge	Drilling	Bolt Circle	$\pm \frac{1}{16}''$
	Slip-on and Lap Joint	10" and smaller $+\frac{1}{32}'' - 0''$ 12" and larger $+\frac{1}{16}'' - 0''$		Bolt hole spacing	$\pm \frac{1}{32}''$
Diameter of Contact Face (C)	$\frac{1}{16}''$ Raised Face	$\pm \frac{1}{32}''$	Overall Height (E)	On flanges 18" and smaller	$+\frac{1}{8}''^{(1)} - \frac{1}{32}''^{(1)}$
	$\frac{1}{4}''$ Raised Face, Tongue and Groove, or Male and Female	$\pm \frac{1}{64}''$		On flanges larger than 18"	$+\frac{3}{16}''^{(1)} - \frac{1}{16}''^{(1)}$
Diameter of Counterbore	Same as for Inside Diameter		Thickness (B)	18" and smaller	$+\frac{1}{8}'' - 0''$
				Over 18"	$+\frac{3}{16}'' - 0''$
				Where allowance has been left on face for finish: All sizes	$+\frac{1}{8}''^{(1)} - \frac{1}{16}''^{(1)}$

<sup>(1)</sup> This tolerance not covered by ANSI B16.5. Dimensions are approximate.

## welding neck flanges

### ANSI B16.5

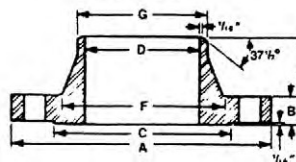

Outside Diameter (A)	When O. D. is 24" or less	$\pm \frac{1}{16}''^{(1)}$	Drilling	Bolt Circle	$\pm \frac{1}{16}''$
	When O. D. is over 24"	$\pm \frac{1}{8}''^{(1)}$		Bolt hole spacing	$\pm \frac{1}{32}''$
Inside Diameter (D)	10" and smaller	$\pm \frac{1}{32}''$	Eccentricity between bolt circle diameter and machined facing diameter	2 1/2" and smaller	$\frac{1}{32}''$ Max.
	12" to 18"	$\pm \frac{1}{16}''$		3" and larger	$\frac{1}{16}''$ Max.
	Over 18"	$+\frac{1}{8}'' - \frac{1}{16}''$		Width of Land	All sizes
Diameter of Contact Face (C)	$\frac{1}{16}''$ Raised Face	$\pm \frac{1}{32}''$	Angle of Hub Bevel	All sizes	$\pm 2\frac{1}{2}^\circ$
	$\frac{1}{4}''$ Raised Face, Tongue and Groove, or Male and Female	$\pm \frac{1}{64}''$		Overall Height (E)	10" and smaller
Diameter of Hub at Point of Welding (G)	5" and smaller	$+\frac{3}{32}'' - \frac{1}{32}''$	Thickness (B)		12" and larger
	6" and larger	$+\frac{5}{32}'' - \frac{1}{32}''$		18" and smaller	$+\frac{1}{8}'' - 0''$
Diameter of Hub at Base (F)	When "F" is 24" and smaller	$\pm \frac{1}{16}''^{(1)}$	Where allowance has been left on face for finish: All sizes	Over 18"	$+\frac{3}{16}'' - 0''$
	When "F" is over 24"	$\pm \frac{1}{8}''^{(1)}$		$+\frac{1}{8}''^{(1)} - \frac{1}{16}''^{(1)}$	

<sup>(1)</sup> This tolerance not covered by ANSI B16.5. Dimensions are approximate.



## AMERICAN STANDARD FLANGE FACINGS

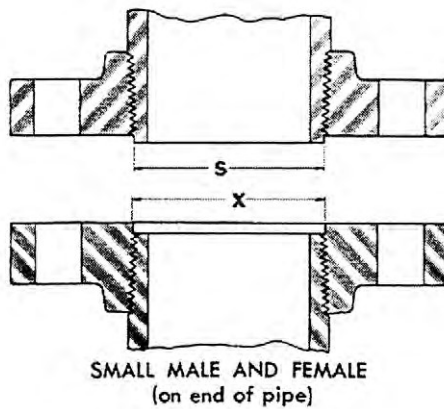
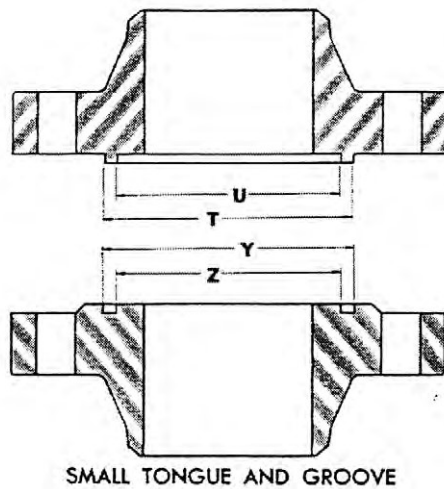
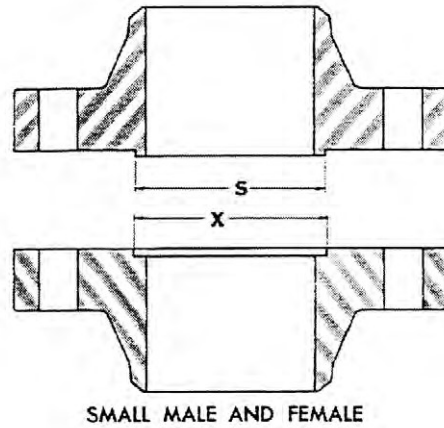
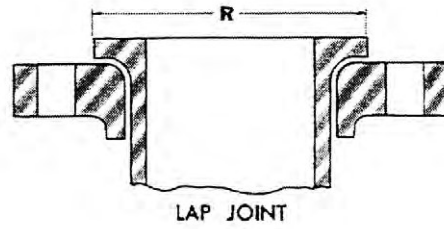
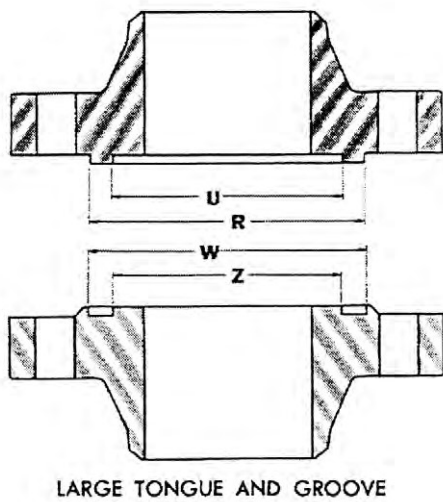
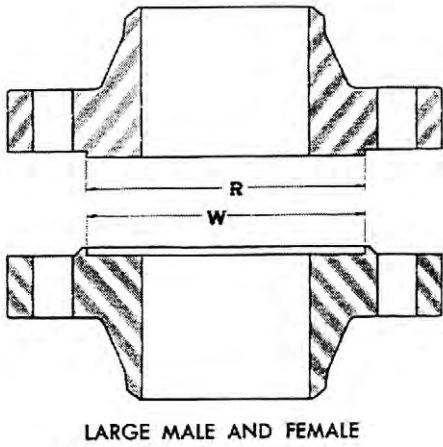
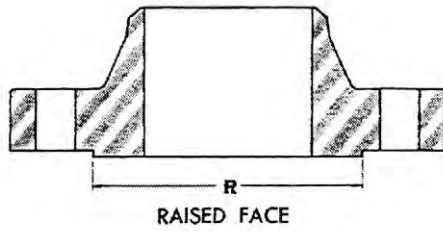

## AMERICAN STANDARD FLANGE FACINGS

For 150, 300, 400, 600, 900, 1500 and 2500 Lb. Flanges

Nominal Pipe Size	Outside Diameter <sup>2</sup>			I.D. of Large and Small Tongue <sup>3,5</sup>	Outside Diameter <sup>3</sup>			I.D. of Large and Small Groove <sup>3,5</sup>	Height		Depth of Groove or Female
	Raised Face, Lap Joint, Large Male and Large Tongue <sup>2</sup>	Small Male <sup>4,5</sup>	Small Tongue <sup>3</sup>		Large Female and Large Groove <sup>5</sup>	Small Female <sup>4,5</sup>	Small Groove <sup>5</sup>		Raised Face 150 and 300-Pound Standards <sup>1</sup>	Raised Face, Large and Small Male and Tongue 400, 600, 900, 1500 and 2500- Pound Standards <sup>2</sup>	
1/2	1 3/8	2 3/32	1 3/8	1	1 7/16	2 5/32	1 7/16	1 5/16	1/16	1/4	3/16
3/4	1 11/16	1 3/16	1 11/16	1 1/16	1 3/4	1	1 3/4	1 1/4	1/16	1/4	3/16
1	2	1 3/16	1 3/8	1 1/2	2 1/16	1 1/4	1 15/16	1 7/16	1/16	1/4	3/16
1 1/4	2 1/2	1 1/2	2 1/4	1 7/8	2 5/16	1 9/16	2 3/16	1 13/16	1/16	1/4	3/16
1 1/2	2 7/8	1 3/4	2 1/2	2 1/8	2 5/16	1 13/16	2 7/16	2 1/16	1/16	1/4	3/16
2	3 3/8	2 1/4	3 1/4	2 7/8	3 11/16	2 3/16	3 3/16	2 13/16	1/16	1/4	3/16
2 1/2	4 1/8	2 11/16	3 3/4	3 3/8	4 1/16	2 3/4	3 13/16	3 3/16	1/16	1/4	3/16
3	5	3 3/16	4 3/8	4 1/4	5 1/16	3 3/8	4 11/16	4 3/16	1/16	1/4	3/16
3 1/2	5 1/2	3 13/16	5 1/8	4 3/4	5 5/16	3 7/8	5 3/16	4 11/16	1/16	1/4	3/16
4	6 3/16	4 3/16	5 11/16	5 3/16	6 1/4	4 3/8	5 3/4	5 1/8	1/16	1/4	3/16
5	7 3/16	5 3/8	6 13/16	6 3/16	7 3/8	5 7/16	6 7/8	6 1/4	1/16	1/4	3/16
6	8 1/2	6 3/8	8	7 1/2	8 7/16	6 7/16	8 1/16	7 7/16	1/16	1/4	3/16
8	10 3/8	8 3/8	10	9 3/8	10 11/16	8 7/16	10 1/16	9 3/16	1/16	1/4	3/16
10	12 3/4	10 1/2	12	11 1/4	12 13/16	10 9/16	12 1/16	11 3/16	1/16	1/4	3/16
12	15	12 1/2	14 1/4	13 1/2	15 1/16	12 2/16	14 3/16	13 3/16	1/16	1/4	3/16
14	16 1/4	13 3/4	15 1/2	14 3/4	16 3/16	13 13/16	15 5/16	14 11/16	1/16	1/4	3/16
16	18 1/2	15 3/4	17 3/8	16 3/4	18 7/16	15 13/16	17 11/16	16 11/16	1/16	1/4	3/16
18	21	17 3/4	20 1/8	19 1/4	21 1/16	17 17/16	20 3/16	19 3/16	1/16	1/4	3/16
20	23	19 3/4	22	21	23 1/16	19 13/16	22 1/16	20 15/16	1/16	1/4	3/16
24	27 1/4	23 3/4	26 1/4	25 1/4	27 3/16	23 13/16	26 3/16	25 3/16	1/16	1/4	3/16

All dimensions are in inches.

<sup>1</sup> Regular facing for 150 and 300 Lb. steel flanged fittings and flange standards is a 1/16 inch raised face included in the minimum flange thickness. A 1/16 inch raised face is also permitted on the 400, 600, 900, 1500 and 2500 Lb. flange standards, but it must be added to the minimum flange thickness.

<sup>2</sup> Regular facing for 400, 600, 900, 1500 and 2500 Lb. flange standards is a 1/4 inch raised face not included in minimum flange thickness dimensions.

<sup>3</sup> A tolerance of plus or minus 0.016 inch (1/64 inch) is allowed on the inside and outside diameters of all facings.

<sup>4</sup> Care should be taken in the use of joints of these dimensions, (they apply particularly on lines where the joint is made on the end of pipe) to insure that pipe used is thick enough to permit sufficient bearing surface to prevent crushing the gasket. Threaded companion flanges are furnished with plain face and are threaded with American Standard Locknut Thread.

<sup>5</sup> Gaskets for male-female and tongue-groove joints shall cover the bottom of the recess with minimum clearances taking into account the tolerances prescribed in Note 3.



## FACING DIMENSIONS FOR RING JOINT FLANGES

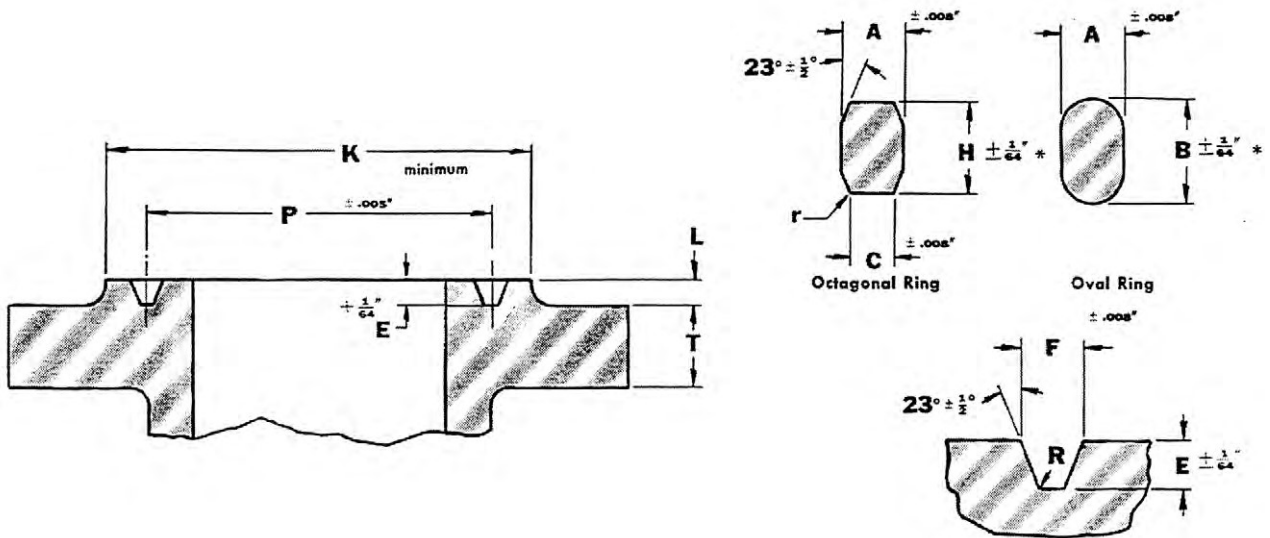

### 150 LB. STANDARD

Nominal Pipe Size	Pitch Diam. Ring & Groove	GROOVE DIMENSIONS			RING DIMENSIONS				Diam. Raised Face or Lap	Distance Between Flanges When Ring is Compressed	Ring and Groove Number
		Width	Depth	Radius	Width	Height		Width of Flat			
						Oval	Octagonal				
P	F	E	R	A	B	H	C	K			
1	1 7/8	1 1/32	1/4	1/32	5/16	5/16	1/2	.206	2 1/2	5/32	R 15
1 1/4	2 1/4	1 1/32	1/4	1/32	5/16	5/16	1/2	.206	2 7/8	5/32	R 17
1 1/2	2 5/8	1 1/32	1/4	1/32	5/16	5/16	1/2	.206	3 1/4	5/32	R 19
2	3 1/4	1 1/32	1/4	1/32	5/16	5/16	1/2	.206	4	5/32	R 22
2 1/2	4	1 1/32	1/4	1/32	5/16	5/16	1/2	.206	4 3/4	5/32	R 25
3	4 1/2	1 1/32	1/4	1/32	5/16	5/16	1/2	.206	5 1/4	5/32	R 29
3 1/2	5 1/8	1 1/32	1/4	1/32	5/16	5/16	1/2	.206	6 1/8	5/32	R 33
4	5 3/4	1 1/32	1/4	1/32	5/16	5/16	1/2	.206	6 3/4	5/32	R 36
5	6 3/4	1 1/32	1/4	1/32	5/16	5/16	1/2	.206	7 3/8	5/32	R 40
6	7 3/8	1 1/32	1/4	1/32	5/16	5/16	1/2	.206	8 3/8	5/32	R 43
8	9 3/4	1 1/32	1/4	1/32	5/16	5/16	1/2	.206	10 3/4	5/32	R 48
10	12	1 1/32	1/4	1/32	5/16	5/16	1/2	.206	13	5/32	R 52
12	15	1 1/32	1/4	1/32	5/16	5/16	1/2	.206	16	5/32	R 56
14	15 5/8	1 1/32	1/4	1/32	5/16	5/16	1/2	.206	16 3/4	1/8	R 59
16	17 3/8	1 1/32	1/4	1/32	5/16	5/16	1/2	.206	19	1/8	R 64
18	20 3/8	1 1/32	1/4	1/32	5/16	5/16	1/2	.206	21 1/2	1/8	R 68
20	22	1 1/32	1/4	1/32	5/16	5/16	1/2	.206	23 1/2	1/8	R 72
22	24 1/4	1 1/32	1/4	1/32	5/16	- -	1/2	.206	25 1/2	1/8	R 80
24	26 1/2	1 1/32	1/4	1/32	5/16	5/16	1/2	.206	28	1/8	R 76

All dimensions are in inches. Unless otherwise specified by the purchaser, Ring Type Joint Flanges will be furnished in accordance with these details. The depth of groove is added to the minimum flange thickness. Raised face "L" is equal to groove dimension "E" but is not subject to tolerances for "E".

\* A plus tolerance of 3/64 in. for heights B and H is permitted providing the variation in the height of any given ring does

not exceed 1/64 in. throughout its entire circumference.

Dimension "R" is max.

Radius "r" is 1/16" for ring widths 7/8" and less and 3/32" for ring widths 1" and over.

† For Ring Joints with Lapped Flanges in the 300, 400 and 600 lb. standards, Ring and Groove Number R30 are used instead of R31. Dimensions of Ring R30 are identical with those of R31, except that the pitch diameter is 4 5/8".



# Facing Dimensions for Ring Joint Flanges (continued)

## 300, 400 and 600 LB. STANDARDS (Ring Joint Facing Dimensions—Continued)

Nominal Pipe Size	Pitch Diam. Ring & Groove	GROOVE DIMENSIONS			RING DIMENSIONS				Diam. Raised Face or Lap	Distance Between Flanges When Ring is Compressed			Ring and Groove Number
					Width	Depth	Radius	Width		Height		Width of Flat	
		P	F	E						R	A		
1/2	1 1/32	3/32	7/32	1/32	1/4	3/16	3/8	.170	2	1/8	1/8	1/8	R 11
3/4	1 1/16	1 1/32	1/4	1/32	3/16	3/16	1/2	.206	2 1/2	3/32	3/32	3/32	R 13
1	2	1 1/32	1/4	1/32	3/16	3/16	1/2	.206	2 3/4	3/32	3/32	3/32	R 16
1 1/4	2 3/8	1 1/32	1/4	1/32	3/16	3/16	1/2	.206	3 3/8	3/32	3/32	3/32	R 18
1 1/2	2 11/16	1 1/32	1/4	1/32	3/16	3/16	1/2	.206	3 3/16	3/32	3/32	3/32	R 20
2	3 1/4	1 1/32	3/16	1/32	3/16	1 1/16	5/8	.305	4 1/4	7/32	3/16	3/16	R 23
2 1/2	4	1 5/32	3/16	1/32	3/16	1 1/16	5/8	.305	5	7/32	3/16	3/16	R 26
3 †	4 7/8	1 5/32	3/16	1/32	3/16	1 1/16	5/8	.305	5 3/4	7/32	3/16	3/16	R 31
3 1/2	5 3/16	1 5/32	3/16	1/32	3/16	1 1/16	5/8	.305	6 1/4	7/32	3/16	3/16	R 34
4	5 7/8	1 5/32	3/16	1/32	3/16	1 1/16	5/8	.305	6 7/8	7/32	7/32	3/16	R 37
5	7 1/8	1 5/32	3/16	1/32	3/16	1 1/16	5/8	.305	8 1/4	7/32	7/32	3/16	R 41
6	8 5/16	1 5/32	3/16	1/32	3/16	1 1/16	5/8	.305	9 1/2	7/32	7/32	3/16	R 45
8	10 5/8	1 5/32	3/16	1/32	3/16	1 1/16	5/8	.305	11 7/8	7/32	7/32	3/16	R 49
10	12 3/4	1 5/32	3/16	1/32	3/16	1 1/16	5/8	.305	14	7/32	7/32	3/16	R 53
12	15	1 5/32	3/16	1/32	3/16	1 1/16	5/8	.305	16 1/4	7/32	7/32	3/16	R 57
14	16 1/2	1 5/32	3/16	1/32	3/16	1 1/16	5/8	.305	18	7/32	7/32	3/16	R 61
16	18 1/2	1 5/32	3/16	1/32	3/16	1 1/16	5/8	.305	20	7/32	7/32	3/16	R 65
18	21	1 5/32	3/16	1/32	3/16	1 1/16	5/8	.305	22 3/8	7/32	7/32	3/16	R 69
20	23	1 7/32	3/8	1/16	1/2	3/4	1 1/16	.341	25	7/32	7/32	3/16	R 73
22	25	1 9/32	7/16	1/16	3/4	- -	3/4	.377	27	- -	- -	- -	R 81
24	27 1/4	1 11/32	7/16	1/16	3/4	3/8	1 1/16	.413	29 1/2	1/4	1/4	7/32	R 77
MSS—SP44 Classes 300, 400 and 600													
26	29 1/2	2 1/32	1/2	1/16	3/4	- -	1 5/16	.485	31 7/8	This dimension not shown for 22" size in ASA Standard or for sizes 26" through 36" in MSS-SP44			R 93
28	31 1/2	2 5/32	1/2	1/16	3/4	- -	1 5/16	.485	33 7/8				R 94
30	33 3/4	2 9/32	1/2	1/16	3/4	- -	1 5/16	.485	36 1/8				R 95
32	36	2 11/32	9/16	1/16	7/8	- -	1 1/16	.583	38 3/4				R 96
34	38	2 13/32	9/16	1/16	7/8	- -	1 1/16	.583	40 3/4				R 97
36	40 1/4	2 15/32	9/16	1/16	7/8	- -	1 1/16	.583	43				R 98

## 900 LB. STANDARD (for sizes 1/2" through 2 1/2", use 1500 lb. Standard dimensions)

3	4 7/8	1 1/32	3/16	1/32	3/16	1 1/16	5/8	.305	6 1/8	- -	3/32	- -	R 31
4	5 5/8	1 1/32	3/16	1/32	3/16	1 1/16	5/8	.305	7 1/8	- -	3/32	- -	R 37
5	7 1/8	1 1/32	3/16	1/32	3/16	1 1/16	5/8	.305	8 1/2	- -	3/32	- -	R 41
6	8 5/16	1 1/32	3/16	1/32	3/16	1 1/16	5/8	.305	9 1/2	- -	3/32	- -	R 45
8	10 3/8	1 1/32	3/16	1/32	3/16	1 1/16	5/8	.305	12 1/8	- -	3/32	- -	R 49
10	12 3/4	1 1/32	3/16	1/32	3/16	1 1/16	5/8	.305	14 1/4	- -	3/32	- -	R 53
12	15	1 1/32	3/16	1/32	3/16	1 1/16	5/8	.305	16 1/2	- -	3/32	- -	R 57
14	16 1/2	2 1/32	7/16	1/16	3/8	7/8	1 3/16	.413	18 3/8	- -	3/32	- -	R 62
16	18 1/2	2 1/32	7/16	1/16	3/8	7/8	1 3/16	.413	20 3/8	- -	3/32	- -	R 66
18	21	2 5/32	1/2	1/16	3/4	1	1 5/16	.485	23 3/8	- -	3/16	- -	R 70
20	23	2 5/32	1/2	1/16	3/4	1	1 5/16	.485	25 1/2	- -	3/16	- -	R 74
24	27 1/4	1 1/16	5/8	3/32	1	1 1/16	1 1/4	.681	30 3/8	- -	7/32	- -	R 78
MSS—SP44 Class 900													
26	29 1/2	1 3/16	1 1/16	3/32	1 1/8	- -	1 3/8	.780	32 3/4	This dimension not shown in MSS-SP44			R 100
28	31 1/2	1 1/16	1 1/16	3/32	1 1/4	- -	1 1/2	.879	35				R 101
30	33 3/4	1 1/16	1 1/16	3/32	1 1/4	- -	1 1/2	.879	37 1/4				R 102
32	36	1 3/16	1 1/16	3/32	1 1/4	- -	1 1/2	.879	39 1/2				R 103
34	38	1 7/16	1 3/16	3/32	1 3/8	- -	1 5/8	.977	42				R 104
36	40 1/4	1 7/16	1 3/16	3/32	1 3/8	- -	1 5/8	.977	44 1/4				R 105

For applicable footnotes see opposite page.

## FACING DIMENSIONS FOR RING JOINT FLANGES

(Continued from preceding page)

### 1500 LB. STANDARD

Nominal Pipe Size	Pitch Diam. Ring & Groove	GROOVE DIMENSIONS			RING DIMENSIONS				Diam. Raised Face or Lap	Distance Between Flanges When Ring is Compressed	Ring and Groove Number
		Width	Depth	Radius	Width	Height		Width of Flat			
						Oval	Octagonal				
		P	F	E	R	A	B	H			
1/2	1 1/16	1 1/32	1/4	1/32	3/16	9/16	1/2	.206	2 3/8	5/32	R 12
3/4	1 3/4	1 1/32	1/4	1/32	3/16	9/16	1/2	.206	2 3/8	5/32	R 14
1	2	1 1/32	1/4	1/32	5/16	9/16	1/2	.206	2 13/16	5/32	R 16
1 1/4	2 3/8	1 1/32	1/4	1/32	5/16	9/16	1/2	.206	3 3/16	5/32	R 18
1 1/2	2 11/16	1 1/32	1/4	1/32	5/16	9/16	1/2	.206	3 5/8	5/32	R 20
2	3 3/4	1 5/32	5/16	1/32	7/16	1 1/16	5/8	.305	4 7/8	1/8	R 24
2 1/2	4 1/4	1 5/32	5/16	1/32	7/16	1 1/16	5/8	.305	5 3/8	1/8	R 27
3	5 3/8	1 5/32	5/16	1/32	7/16	1 1/16	5/8	.305	6 5/8	1/8	R 35
4	6 3/4	1 5/32	5/16	1/32	7/16	1 1/16	5/8	.305	7 3/8	1/8	R 39
5	7 5/8	1 5/32	5/16	1/32	7/16	1 1/16	5/8	.305	9	1/8	R 44
6	8 7/8	1 7/32	3/8	1/16	1/2	3/4	1 1/16	.341	9 3/4	1/8	R 46
8	10 3/8	2 1/32	7/16	1/16	5/8	7/8	1 3/16	.413	12 1/2	5/32	R 50
10	12 3/4	2 1/32	7/16	1/16	5/8	7/8	1 3/16	.413	14 3/8	5/32	R 54
12	15	2 9/32	9/16	1/16	7/8	1 1/8	1 1/16	.583	17 1/4	3/16	R 58
14	16 1/2	1 1/16	3/8	3/32	1	1 1/16	1 1/4	.681	19 1/4	7/32	R 63
16	18 1/2	1 3/16	1 1/16	3/32	1 1/8	1 7/16	1 3/8	.780	21 1/2	5/16	R 67
18	21	1 3/16	1 1/16	3/32	1 1/8	1 7/16	1 3/8	.780	24 1/8	5/16	R 71
20	23	1 5/16	1 1/16	3/32	1 1/4	1 9/16	1 1/2	.879	26 1/2	3/8	R 75
24	27 1/4	1 7/16	1 3/16	3/32	1 3/8	1 3/4	1 5/8	.977	31 1/4	7/16	R 79

### 2500 LB. STANDARD

Nominal Pipe Size	Pitch Diam. Ring & Groove	GROOVE DIMENSIONS			RING DIMENSIONS				Diam. Raised Face or Lap	Distance Between Flanges When Ring is Compressed	Ring and Groove Number
		Width	Depth	Radius	Width	Height		Width of Flat			
						Oval	Octagonal				
		P	F	E	R	A	B	H			
1/2	1 11/16	1 1/32	1/4	1/32	5/16	9/16	1/2	.206	2 7/16	5/32	R 13
3/4	2	1 1/32	1/4	1/32	5/16	9/16	1/2	.206	2 7/8	5/32	R 16
1	2 3/8	1 1/32	1/4	1/32	5/16	9/16	1/2	.206	3 1/4	5/32	R 18
1 1/4	2 27/32	1 5/32	5/16	1/32	7/16	1 1/16	5/8	.305	4	1/8	R 21
1 1/2	3 1/4	1 5/32	5/16	1/32	7/16	1 1/16	5/8	.305	4 1/2	1/8	R 23
2	4	1 5/32	5/16	1/32	7/16	1 1/16	5/8	.305	5 1/4	1/8	R 26
2 1/2	4 3/8	1 7/32	3/8	1/16	1/2	3/4	1 1/16	.341	5 7/8	1/8	R 28
3	5	1 7/32	3/8	1/16	1/2	3/4	1 1/16	.341	6 3/8	1/8	R 32
4	6 3/16	2 1/32	7/16	1/16	5/8	7/8	1 1/16	.413	8	5/32	R 38
5	7 1/2	2 3/32	1/2	1/16	3/4	1	1 5/16	.485	9 1/2	5/32	R 42
6	9	2 9/32	1/2	1/16	3/4	1	1 5/16	.485	11	5/32	R 47
8	11	2 9/32	9/16	1/16	7/8	1 1/8	1 1/16	.583	13 3/8	3/16	R 51
10	13 1/2	1 3/16	1 1/16	3/32	1 1/8	1 7/16	1 3/4	.780	16 3/4	1/4	R 55
12	16	1 5/16	1 1/16	3/32	1 1/4	1 9/16	1 1/2	.879	19 1/2	5/16	R 60

All dimensions are in inches. Unless otherwise specified by the purchaser, Ring Type Joint Flanges will be furnished in accordance with these details.

The depth of groove is added to the minimum flange thickness. Raised face "L" is equal to groove dimension "E" but is not subject to tolerances for "E".

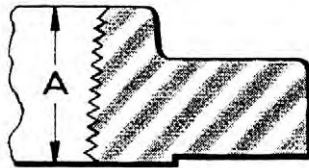

150 LB. STANDARD  
WITH 1/16" RAISED FACE

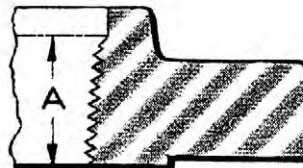

300 LB. STANDARD  
WITH 1/16" RAISED FACE

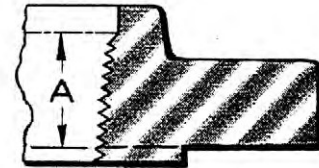

400 LB. STANDARD  
AND HEAVIER  
WITH 1/4" RAISED OR MALE FACE

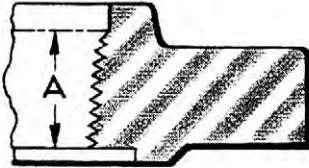

ALL STANDARDS  
WITH FEMALE FACE

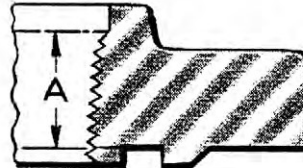

ALL STANDARDS  
WITH GROOVE FACE

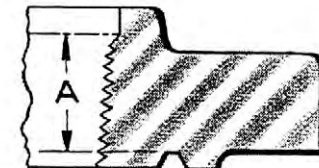

ALL STANDARDS  
WITH RING JOINT FACE

Nominal Pipe Size	A—THREAD LENGTHS, INCHES						
	150 Lb.	300 Lb.	400 Lb.	600 Lb.	900 Lb.	1500 Lb.	2500 Lb.
1/2	5/8	5/8	5/8	5/8	3/4	3/4	1 1/8
3/4	5/8	5/8	5/8	5/8	1	1	1 1/4
1	1 1/16	1 1/16	1 1/16	1 1/16	1 1/8	1 1/8	1 3/8
1 1/4	1 3/16	1 3/16	1 3/16	1 3/16	1 3/16	1 3/16	1 1/2
1 1/2	7/8	7/8	7/8	7/8	1 1/4	1 1/4	1 3/4
2	1	1 1/8	1 1/8	1 1/8	1 1/2	1 1/2	2
2 1/2	1 1/8	1 1/4	1 1/4	1 1/4	1 7/8	1 7/8	2 1/4
3	1 3/16	1 1/4	1 3/8	1 3/8	1 5/8	2	2 1/2
3 1/2	1 1/4	1 7/16	1 1/2	1 1/2	--	--	--
4	1 5/16	1 7/16	1 7/16	1 5/8	1 7/8	2 1/4	2 3/4
5	1 7/16	1 11/16	1 11/16	1 7/8	2 1/8	2 1/2	3
6	1 1/2	1 13/16	1 13/16	2	2 1/4	2 3/4	3 1/4
8	1 3/4	2	2	2 3/8	2 1/2	3	3 3/4
10	1 15/16	2 1/8	2 3/16	2 1/2	2 13/16	3 3/16	4 1/4
12	2 1/16	2 3/8	2 3/8	2 3/4	3	3 5/8	4 3/4
14	2 1/4	2 1/2	2 1/2	2 7/8	3 1/4	--	--
16	2 1/2	2 11/16	2 11/16	3 1/16	3 3/8	--	--
18	2 11/16	2 3/4	2 3/4	3 1/8	3 1/2	--	--
20	2 7/8	2 7/8	2 7/8	3 1/4	3 5/8	--	--
24	3 1/4	3 1/4	3 1/4	3 3/4	4	--	--

Flanges shall be topped with American Standard Taper Pipe Threads in accordance with ASA Standard B2.1 (see next page) but shall have longer thread lengths in proportion to the flange thickness for high pressure-temperature services. Pitch diameter  $E_1$ , at intersection of chamfer cone, and pitch

diameter of thread cone are maintained. Gauging notch of the plug gauge should come flush at this point with a manufacturing tolerance of  $\pm$  one turn. Pitch diameter at small end of thread  $E_0$ , is made proportionally smaller in flanges.



# Threading Practice for American Standard Flanges (continued)

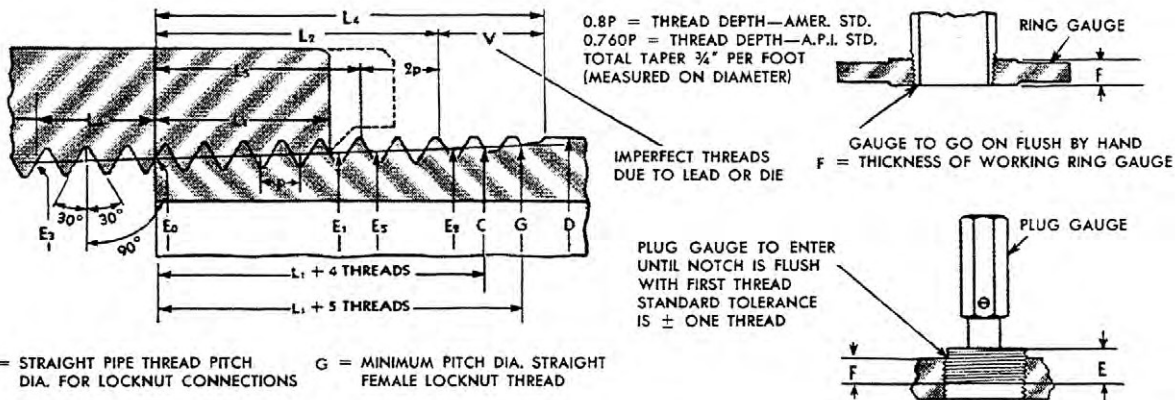

Nominal Pipe Size	Outside Diameter of Pipe	Threads Per Inch	Pitch of Thread	Pitch Diameter at Beginning of External Threads	Handtight Engagement		Effective Thread External		Wrench Make-Up Length for Internal Thread		Overall Length External Thread
					Length	Pitch Diameter	Length	Pitch Diameter	Length	Pitch Diameter	
					L1†	E1	L2†	E2	L3	E3	
1/8	.405	27	.0370	.3635	.180	.3748	.2639	.3800	.1111	.3566	.3924
1/4	.540	18	.0556	.4774	.200	.4899	.4018	.5025	.1667	.4670	.5946
3/8	.675	18	.0556	.6120	.240	.6270	.4078	.6375	.1667	.6016	.6006
1/2	.840	14	.0714	.7584	.320	.7784	.5337	.7918	.2143	.7450	.7815
3/4	1.050	14	.0714	.9677	.339	.9889	.5457	1.0018	.2143	.9543	.7935
1	1.315	11 1/2	.0870	1.2136	.400	1.2386	.6828	1.2563	.2609	1.1973	.9845
1 1/4	1.660	11 1/2	.0870	1.5571	.420	1.5834	.7068	1.6013	.2609	1.5408	1.0085
1 1/2	1.900	11 1/2	.0870	1.7961	.420	1.8223	.7235	1.8413	.2609	1.7798	1.0252
2	2.375	11 1/2	.0870	2.2690	.436	2.2963	.7565	2.3163	.2609	2.2527	1.0582
2 1/2	2.875	8	.1250	2.7195	.682	2.7622	1.1375	2.7906	.2500	2.7039	1.5712
3	3.500	8	.1250	3.3406	.766	3.3885	1.2000	3.4156	.2500	3.3250	1.6337
3 1/2	4.000	8	.1250	3.8375	.821	3.8888	1.2500	3.9156	.2500	3.8219	1.6837
4	4.500	8	.1250	4.3344	.844	4.3871	1.3000	4.4156	.2500	4.3188	1.7337
* 4 1/2	5.000	8	.1250	4.8313	.875	4.8859	1.3500	4.8418	--	--	--
5	5.563	8	.1250	5.3907	.937	5.4493	1.4063	5.4786	.2500	5.3751	1.8400
6	6.625	8	.1250	6.4461	.958	6.5060	1.5125	6.5406	.2500	6.4305	1.9462
* 7	7.625	8	.1250	7.4398	1.000	7.5023	1.6125	7.4524	--	--	--
8	8.625	8	.1250	8.4336	1.063	8.5000	1.7125	8.5406	.2500	8.4180	2.1462
* 9	9.625	8	.1250	9.4273	1.130	9.4980	1.8125	9.4415	--	--	--
10	10.750	8	.1250	10.5453	1.210	10.6209	1.9250	10.6656	.2500	10.5297	2.3587
* 11	11.750	8	.1250	11.5391	1.285	11.6194	2.0250	11.5549	--	--	--
12	12.750	8	.1250	12.5328	1.360	12.6178	2.1250	12.6656	.2500	12.5172	2.5587
14	14.000	8	.1250	13.7750	1.562	13.8726	2.2500	13.9156	.2500	13.7594	2.6837
* 15	15.000	8	.1250	14.7688	1.687	14.8742	2.3500	14.8772	--	--	--
16	16.000	8	.1250	15.7625	1.812	15.8758	2.4500	15.9156	.2500	15.7469	2.8837
* 17	17.000	8	.1250	16.7563	1.900	16.8750	2.5500	16.7762	--	--	--
18	18.000	8	.1250	17.7500	2.000	17.8750	2.6500	17.9156	.2500	17.7344	3.0837
20	20.000	8	.1250	19.7375	2.125	19.8703	2.8500	19.9156	.2500	19.7219	3.2837
* 22	22.000	8	.1250	21.7250	2.250	21.8656	3.0500	21.7488	--	--	--
24	24.000	8	.1250	23.7125	2.375	23.8609	3.2500	23.9156	.2500	23.6969	3.6837

Data per American Standard ASA B2.1-1945 (for taper pipe threads) and API Standard 6A (for line pipe threads).  
 \* Sizes discontinued in American Standards—listed for reference only.  
 † Also length of plug gauge.  
 ‡ Length of ring gauge and length from gauging notch to small end of plug gauge.  
 The American Standard Pipe Thread and the API Standard Line Pipe Thread are interchangeable.

## Seamless Carbon Steel

## GRADE B

Nominal Pipe Size	Maximum Allowable Working Pressures at -20F to 650F▲												
	Sched. 10 <sup>m</sup>	Sched. 20	Sched. 30	Std. Wall	Sched. 40	Sched. 60	Extra Strong	Sched. 80	Sched. 100	Sched. 120	Sched. 140	Sched. 160	XX Strong
½	--	--	--	1694	1694	--	3036	3036	--	--	--	4551	9223
¾	659	--	--	1450	1450	--	2589	2589	--	--	--	4505	7531
1	1065	--	--	1578	1578	--	2601	2601	--	--	--	4290	7150
1¼	556	--	--	1069	1069	--	1941	1941	--	--	--	3001	5593
1½	486	--	--	1004	1004	--	1821	1821	--	--	--	3091	5114
2	388	--	--	903	903	--	1659	1659	--	--	--	3225	4475
2½	421	--	--	1214	1214	--	1936	1936	--	--	--	2963	4936
3	346	--	--	1094	1094	--	1773	1773	--	--	--	2933	4405
3½	303	--	--	1023	1023	--	1671	1671	--	--	--	--	--
4	269	--	--	974	974	--	1598	1598	--	2243	--	2868	3858
5	284	--	--	888	888	--	1475	1475	--	2123	--	2791	3485
6	239	--	--	833	833	--	1473	1473	--	2038	--	2738	3414
8	225	543	628	770	770	1038	1343	1343	1649	2068	2388	2715	2605
10	224	434	578	723	723	1070	1070	1311	1641	1975	2406	2754	--
12	219	366	534	630	696	1033	898	1305	1653	2009	2295	2735	--
14	333	451	573	573	693	999	816	1311	1690	2013	2341	2675	--
16	291	395	500	500	711	980	711	1305	1638	1975	2378	2669	--
18	258	350	538	444	725	1013	631	1303	1648	1998	2303	2665	--
20	233	399	568	399	693	995	568	1299	1653	1970	2338	2663	--
22	211	--	--	363	--	--	515	--	--	--	--	--	--
24	194	331	541	331	683	1004	471	1295	1664	2003	2309	2656	--
26	--	--	--	306	--	--	435	--	--	--	--	--	--
30	209	376	488	265	--	--	376	--	--	--	--	--	--
36	--	--	--	220	--	--	314	--	--	--	--	--	--
42	--	--	--	189	--	--	269	--	--	--	--	--	--

▲ For allowable working pressures at higher temperatures, multiply listed values by the following factors:

### GRADE A

Temperature	700F	750F	800F	850F	900F
Multiplying Factor	.971	.892	.750	.708	.417

### GRADE B

Temperature	700F	750F	800F	850F	900F
Multiplying Factor	.956	.863	.720	.520	.333

■ Schedule 10 starts with the 14" size. Values tabulated for smaller sizes refer to "Light Wall" fittings.



# Pressure Temperature Ratings Of Flanges

Y STEELS ▲

Primary Service Pressure Rating		150 lb.	300 lb.	400 lb.	600 lb.	900 lb.	1500 lb.	2500 lb.
Hydrostatic Shell Test Pressures		425	1100	1450	2175	3250	5400	9000
Service Temperatures Degrees F.	Material	MAXIMUM, NON-SHOCK, SERVICE PRESSURE RATINGS, POUNDS PER SQUARE INCH (GAGE)						
-20 to 100 <sup>Δ</sup>	*	275	720	960	1440	2160	3600	6000
	150	255	710	945	1420	2130	3550	5915
	200	240	700	930	1400	2100	3500	5830
250	*	225	690	920	1380	2070	3450	5750
	300	210	680	910	1365	2050	3415	5690
	350	195	675	900	1350	2025	3375	5625
400	*	180	665	890	1330	2000	3330	5550
	450	165	650	870	1305	1955	3255	5430
	500	150	625	835	1250	1875	3125	5210
550	*	140	590	790	1180	1775	2955	4925
	600	130	555	740	1110	1660	2770	4620
	650	120	515	690	1030	1550	2580	4300
700	Carbon Steel	110	470	635	940	1410	2350	3920
	Carbon Moly	110	480	640	960	1440	2400	4000
	½ Cr, ½ Mo	110	480	640	960	1440	2400	4000
	1 Cr, ½ Mo	110	485	645	965	1450	2415	4025
	1 ¼ Cr, ½ Mo	110	485	645	965	1450	2415	4025
	2 Cr, ½ Mo	110	480	640	960	1440	2400	4000
	2 ¼ Cr, 1 Mo	110	485	645	965	1450	2415	4025
	3 Cr, 1 Mo	110	480	640	960	1440	2400	4000
	5 Cr, ½ Mo	110	485	645	965	1450	2415	4025
	5 Cr, ½ Mo, Si	110	480	640	960	1440	2400	4000
	9 Cr, 1 Mo	110	485	645	965	1450	2415	4025

Δ Some of the materials listed herein undergo a decrease in impact resistance to such an extent at subzero temperatures as to be unable to safely resist shock loading, sudden changes of stress, or high stress concentrations. Therefore,

products that are to operate at temperatures of below -20F shall conform to the rules of the applicable Codes under which they are to be used.

\* Includes all of the eleven materials rated for 700° service.

# Pressure Temperature Ratings Of Flanges (continued)

**CARBON AND ALLOY STEELS ▲**

Primary Service Pressure Rating		150 lb.	300 lb.	400 lb.	600 lb.	900 lb.	1500 lb.	2500 lb.
Service Temperatures Degrees F.	Material	MAXIMUM, NON-SHOCK, SERVICE PRESSURE RATINGS, POUNDS PER SQUARE INCH (GAGE)						
750	Carbon Steel	100	425	575	850	1275	2125	3550
	Carbon Moly	100	445	590	890	1330	2220	3700
	½ Cr, ½ Mo	100	445	590	890	1330	2220	3700
	1 Cr, ½ Mo	100	450	600	900	1350	2250	3745
	1¼ Cr, ½ Mo	100	450	600	900	1350	2250	3745
	2 Cr, ½ Mo	100	445	590	890	1330	2220	3700
	2¼ Cr, 1 Mo	100	450	600	900	1350	2250	3745
	3 Cr, 1 Mo	100	445	590	890	1330	2220	3700
	5 Cr, ½ Mo	100	450	600	900	1350	2250	3745
	5 Cr, ½ Mo, Si	100	445	590	890	1330	2220	3700
9 Cr, 1 Mo	100	450	600	900	1350	2250	3745	
800	Carbon Steel	92	365	490	730	1100	1830	3050
	Carbon Moly	92	410	545	815	1225	2040	3400
	½ Cr, ½ Mo	92	410	545	815	1225	2040	3400
	1 Cr, ½ Mo	92	415	555	835	1250	2080	3470
	1¼ Cr, ½ Mo	92	415	555	835	1250	2080	3470
	2 Cr, ½ Mo	92	410	545	815	1225	2040	3400
	2¼ Cr, 1 Mo	92	415	555	835	1250	2080	3470
	3 Cr, 1 Mo	92	410	545	815	1225	2040	3400
	5 Cr, ½ Mo	92	415	555	835	1250	2080	3470
	5 Cr, ½ Mo, Si	92	410	545	815	1225	2040	3400
9 Cr, 1 Mo	92	415	555	835	1250	2080	3470	
850	Carbon Steel	82	300	400	600	900	1500	2500
	Carbon Moly	82	370	495	745	1115	1860	3100
	½ Cr, ½ Mo	82	370	495	745	1115	1860	3100
	1 Cr, ½ Mo	82	385	510	765	1150	1915	3190
	1¼ Cr, ½ Mo	82	385	510	765	1150	1915	3190
	2 Cr, ½ Mo	82	370	495	745	1115	1860	3100
	2¼ Cr, 1 Mo	82	385	510	765	1150	1915	3190
	3 Cr, 1 Mo	82	370	495	745	1115	1860	3100
	5 Cr, ½ Mo	82	385	510	765	1150	1915	3190
	5 Cr, ½ Mo, Si	82	370	495	745	1115	1860	3100
9 Cr, 1 Mo	82	385	510	765	1150	1915	3190	
875	Carbon Steel	75	260	350	525	785	1305	2180
	Carbon Moly	75	355	470	710	1060	1770	2950
	½ Cr, ½ Mo	75	355	470	710	1060	1770	2950
	1 Cr, ½ Mo	75	365	490	735	1100	1830	3055
	1¼ Cr, ½ Mo	75	365	490	735	1100	1830	3055
	2 Cr, ½ Mo	75	355	470	710	1060	1770	2950
	2¼ Cr, 1 Mo	75	365	490	735	1100	1830	3055
	3 Cr, 1 Mo	75	355	470	710	1060	1770	2950
	5 Cr, ½ Mo	75	365	490	735	1100	1830	3055
	5 Cr, ½ Mo, Si	75	355	470	710	1060	1770	2950
9 Cr, 1 Mo	75	365	490	735	1100	1830	3055	
900	Carbon Steel	70	225	295	445	670	1115	1855
	Carbon Moly	70	335	450	670	1010	1680	2800
	½ Cr, ½ Mo	70	335	450	670	1010	1680	2800
	1 Cr, ½ Mo	70	350	465	700	1050	1750	2915
	1¼ Cr, ½ Mo	70	350	465	700	1050	1750	2915
	2 Cr, ½ Mo	70	335	450	670	1010	1680	2800
	2¼ Cr, 1 Mo	70	350	465	700	1050	1750	2915
	3 Cr, 1 Mo	70	335	450	670	1010	1680	2800
	5 Cr, ½ Mo	70	350	465	700	1050	1750	2915
	5 Cr, ½ Mo, Si	70	335	450	670	1010	1680	2800
9 Cr, 1 Mo	70	350	465	700	1050	1750	2915	



# Pressure Temperature Ratings Of Flanges (continued)

**CARBON AND ALLOY STEELS ▲**

Primary Service Pressure Rating		150 lb.	300 lb.	400 lb.	600 lb.	900 lb.	1500 lb.	2500 lb.
Service Temperatures Degrees F.	Material	MAXIMUM, NON-SHOCK, SERVICE PRESSURE RATINGS, POUNDS PER SQUARE INCH (GAGE)						
925	Carbon Steel	60	190	250	375	565	945	1570
	Carbon Moly	60	320	425	635	955	1590	2650
	½ Cr, ½ Mo	60	320	425	635	955	1590	2650
	1 Cr, ½ Mo	60	335	445	665	1000	1665	2775
	1¼ Cr, ½ Mo	60	335	445	665	1000	1665	2775
	2 Cr, ½ Mo	60	320	425	635	955	1590	2650
	2¼ Cr, 1 Mo	60	335	445	665	1000	1665	2775
	3 Cr, 1 Mo	60	320	425	635	955	1590	2650
	5 Cr, ½ Mo	60	335	445	665	1000	1665	2775
	5 Cr, ½ Mo, Si	60	320	425	635	955	1590	2650
9 Cr, 1 Mo	60	335	445	665	1000	1665	2775	
950	Carbon Steel	55	155	205	310	465	770	1285
	Carbon Moly	55	300	400	600	900	1500	2500
	½ Cr, ½ Mo	55	300	400	600	900	1500	2500
	1 Cr, ½ Mo	55	315	420	635	950	1585	2640
	1¼ Cr, ½ Mo	55	315	420	635	950	1585	2640
	2 Cr, ½ Mo	55	300	400	600	900	1500	2500
	2¼ Cr, 1 Mo	55	315	420	635	950	1585	2640
	3 Cr, 1 Mo	55	300	400	600	900	1500	2500
	5 Cr, ½ Mo	55	315	420	635	950	1585	2640
	5 Cr, ½ Mo, Si	55	300	400	600	900	1500	2500
9 Cr, 1 Mo	55	315	420	635	950	1585	2640	
975	Carbon Steel	50	120	160	240	360	600	1000
	Carbon Moly	50	280	370	555	835	1395	2320
	½ Cr, ½ Mo	50	280	370	555	835	1395	2320
	1 Cr, ½ Mo	50	300	400	600	900	1500	2500
	1¼ Cr, ½ Mo	50	300	400	600	900	1500	2500
	2 Cr, ½ Mo	50	280	370	555	835	1390	2315
	2¼ Cr, 1 Mo	50	300	400	600	900	1500	2500
	3 Cr, 1 Mo	50	275	365	550	825	1370	2285
	5 Cr, ½ Mo	50	300	400	600	900	1500	2500
	5 Cr, ½ Mo, Si	50	250	330	495	745	1245	2070
9 Cr, 1 Mo	50	300	400	600	900	1500	2500	
1000	Carbon Steel	40	85	115	170	255	430	715
	Carbon Moly	40	215	285	430	645	1070	1785
	½ Cr, ½ Mo	40	215	285	430	645	1070	1785
	1 Cr, ½ Mo	40	255	345	515	770	1285	2145
	1¼ Cr, ½ Mo	40	265	355	535	800	1335	2230
	2 Cr, ½ Mo	40	215	285	425	635	1065	1770
	2¼ Cr, 1 Mo	40	265	355	535	800	1335	2230
	3 Cr, 1 Mo	40	240	320	480	720	1200	2000
	5 Cr, ½ Mo	40	250	335	500	750	1250	2085
	5 Cr, ½ Mo, Si	40	190	250	375	565	945	1570
9 Cr, 1 Mo	40	290	390	585	875	1455	2430	
1025	1 Cr, ½ Mo	--	215	285	430	645	1070	1785
	1¼ Cr, ½ Mo	--	230	305	455	685	1140	1900
	2 Cr, ½ Mo	--	180	240	355	535	890	1485
	2¼ Cr, 1 Mo	--	235	310	465	700	1165	1945
	3 Cr, 1 Mo	--	215	285	430	645	1070	1785
	5 Cr, ½ Mo	--	215	285	430	645	1070	1785
	5 Cr, ½ Mo, Si	--	155	205	310	465	770	1285
9 Cr, 1 Mo	--	240	320	480	720	1200	2000	



# Pressure Temperature Ratings Of Flanges (continued)

**CARBON AND ALLOY STEELS ▲**

Primary Service Pressure Rating		150 lb.	300 lb.	400 lb.	600 lb.	900 lb.	1500 lb.	2500 lb.
Service Temperatures Degrees F.	Material	MAXIMUM, NON-SHOCK, SERVICE PRESSURE RATINGS, POUNDS PER SQUARE INCH (GAGE)						
1050	1 Cr, ½ Mo	--	170	230	345	515	855	1430
	1 ¼ Cr, ½ Mo	--	190	250	375	565	945	1570
	2 Cr, ½ Mo	--	145	190	290	430	720	1200
	2 ¼ Cr, 1 Mo	--	200	265	400	595	995	1655
	3 Cr, 1 Mo	--	190	250	375	565	945	1570
	5 Cr, ½ Mo	--	180	240	355	535	890	1485
	5 Cr, ½ Mo, Si 9 Cr, 1 Mo	-- --	120 190	160 250	240 375	360 565	600 945	1000 1570
1075	1 Cr, ½ Mo	--	135	180	265	400	670	1115
	1 ¼ Cr, ½ Mo	--	165	215	325	490	815	1355
	2 Cr, ½ Mo	--	120	160	240	355	595	995
	2 ¼ Cr, 1 Mo	--	170	230	345	515	855	1430
	3 Cr, 1 Mo	--	165	215	325	490	815	1355
	5 Cr, ½ Mo	--	145	195	290	435	730	1215
	5 Cr, ½ Mo, Si 9 Cr, 1 Mo	-- --	105 150	135 200	205 300	310 455	515 755	855 1255
1100	1 Cr, ½ Mo	--	95	130	190	290	480	800
	1 ¼ Cr, ½ Mo	--	135	185	275	410	685	1145
	2 Cr, ½ Mo	--	95	125	190	285	470	785
	2 ¼ Cr, 1 Mo	--	145	190	290	430	720	1200
	3 Cr, 1 Mo	--	135	185	275	410	685	1145
	5 Cr, ½ Mo	--	115	150	225	340	565	945
	5 Cr, ½ Mo, Si 9 Cr, 1 Mo	-- --	85 115	115 150	170 225	255 340	430 565	715 945
1125	1 Cr, ½ Mo	--	75	100	150	225	375	620
	1 ¼ Cr, ½ Mo	--	110	150	225	335	555	930
	2 Cr, ½ Mo	--	75	105	155	230	385	645
	2 ¼ Cr, 1 Mo	--	125	165	245	370	615	1030
	3 Cr, 1 Mo	--	115	155	230	345	575	955
	5 Cr, ½ Mo	--	95	125	190	285	470	785
	5 Cr, ½ Mo, Si 9 Cr, 1 Mo	-- --	75 95	100 125	145 190	220 285	370 470	615 785
1150	1 Cr, ½ Mo	--	55	70	105	160	265	445
	1 ¼ Cr, ½ Mo	--	85	115	170	255	430	715
	2 Cr, ½ Mo	--	60	80	120	180	300	500
	2 ¼ Cr, 1 Mo	--	105	135	205	310	515	855
	3 Cr, 1 Mo	--	95	125	185	280	465	770
	5 Cr, ½ Mo	--	75	100	150	225	375	630
	5 Cr, ½ Mo, Si 9 Cr, 1 Mo	-- --	60 75	80 100	125 150	185 225	310 375	515 630
1175	1 Cr, ½ Mo	--	45	60	85	130	220	365
	1 ¼ Cr, ½ Mo	--	65	85	125	190	315	530
	2 Cr, ½ Mo	--	50	65	100	150	255	420
	2 ¼ Cr, 1 Mo	--	85	115	170	255	430	715
	3 Cr, 1 Mo	--	70	95	145	215	360	600
	5 Cr, ½ Mo	--	65	85	125	190	315	530
	5 Cr, ½ Mo, Si 9 Cr, 1 Mo	-- --	50 65	70 85	105 125	155 190	255 315	430 530
1200	1 Cr, ½ Mo	--	35	45	70	105	170	285
	1 ¼ Cr, ½ Mo	--	40	55	80	125	205	345
	2 Cr, ½ Mo	--	40	55	80	125	205	345
	2 ¼ Cr, 1 Mo	--	70	90	135	205	345	570
	3 Cr, 1 Mo	--	50	70	105	155	255	430
	5 Cr, ½ Mo	--	50	70	105	155	255	430
	5 Cr, ½ Mo, Si 9 Cr, 1 Mo	-- --	40 50	55 70	80 105	125 155	205 255	345 430



# Dimensions of Seamless & Weld Pipe

## ANSI B36.10 API Std. 5L

Nominal Wall Thicknesses For All Schedules (with -12.5% values) Number in ( ) in Wall Thickness Column is Minimum Wall.

Nom. Size	Nom. OD	Sch. 5		Sch. 10		Gas Dist.		Sch. 20		STD.		Sch. 30		Sch. 40		XS	
		ID	Wall	ID	Wall	ID	Wall	ID	Wall	ID	Wall	ID	Wall	ID	Wall	ID	Wall
1/8	.405									.269	.068 (.060)			STD.		.215	.095 (.083)
1/4	.540									.364	.088 (.077)			STD.		.302	.119 (.104)
3/8	.675									.493	.091 (.080)			STD.		.423	.126 (.110)
1/2	.840									.622	.109 (.096)			STD.		.546	.147 (.129)
3/4	1.050	.920	.065 (.057)	.884	.083 (.073)					.824	.113 (.099)			STD.		.742	.154 (.135)
1	1.315	1.185	.065 (.057)	1.097	.109 (.095)					1.049	.133 (.116)			STD.		.957	.179 (.157)
1 1/4	1.660	1.530	.065 (.057)	1.442	.109 (.095)					1.380	.140 (.122)			STD.		1.278	.191 (.167)
1 1/2	1.900	1.770	.065 (.057)	1.682	.109 (.095)					1.610	.145 (.127)			STD.		1.500	.200 (.175)
2	2.375	2.245	.065 (.057)	2.157	.109 (.095)					2.067	.154 (.135)			STD.		1.939	.218 (.191)
2 1/2	2.875	2.709	.083 (.073)	2.635	.120 (.105)					2.469	.203 (.178)			STD.		2.323	.276 (.242)
3	3.500	3.334	.083 (.073)	3.260	.120 (.105)					3.068	.216 (.189)			STD.		2.900	.300 (.262)
3 1/2	4.000	3.834	.083 (.073)	3.760	.120 (.105)					3.548	.226 (.198)			STD.		3.364	.318 (.278)
4	4.500	4.334	.083 (.073)	4.260	.120 (.105)	4.124	.188 (.164)			4.026	.237 (.207)			STD.		3.826	.337 (.295)
5	5.563	5.345	.109 (.095)	5.295	.134 (.117)					5.047	.258 (.226)			STD.		4.813	.375 (.328)
6	6.625	6.407	.109 (.095)	6.357	.134 (.117)	6.187	.219 (.192)			6.065	.280 (.245)			STD.		5.761	.432 (.378)
8	8.625	8.407	.109 (.095)	8.329	.148 (.130)	8.187	.219 (.192)	8.125	.250 (.219)	7.981	.322 (.282)	8.071	.277 (.242)	STD.		7.625	.500 (.438)
10	10.750	10.482	.134 (.117)	10.420	.165 (.144)	10.312	.219 (.192)	10.250	.250 (.219)	10.020	.365 (.319)	10.136	.307 (.269)	STD.		9.750	.500 (.438)
12	12.750	12.438	.156 (.136)	12.390	.180 (.158)	12.250	.250 (.219)	12.250	.250 (.219)	12.000	.375 (.328)	12.090	.330 (.289)	11.938	.406 (.355)	11.750	.500 (.438)
14	14.000			13.500	.250 (.219)	13.500	.250 (.219)	13.376	.312 (.273)	13.250	.375 (.328)			13.124	.438 (.383)	13.000	.500 (.438)
16	16.000			15.500	.250 (.219)	15.500	.250 (.219)	15.376	.312 (.273)	15.250	.375 (.328)					15.000	.500 (.438)
18	18.000			17.500	.250 (.219)	17.500	.250 (.219)	17.376	.312 (.273)	17.250	.375 (.328)	17.124	.438 (.383)	16.876	.562 (.492)	17.000	.500 (.438)
20	20.000			19.500	.250 (.219)	19.500	.250 (.219)		STD	19.250	.375 (.328)			18.812	.594 (.519)	19.000	.500 (.438)
22	22.000			21.500	.250 (.219)				STD	21.250	.375 (.328)					21.000	.500 (.438)
24	24.000			23.500	.250 (.219)	23.500	.250 (.219)		STD	23.250	.375 (.328)	22.876	.562 (.492)	22.674	.688 (.602)	23.000	.500 (.438)
26	26.000			25.376	.312 (.273)				XS	25.250	.375 (.328)					25.000	.500 (.438)
28	28.000			27.376	.312 (.273)				XS	27.250	.375 (.328)	26.750	.625 (.547)			27.000	.500 (.438)
30	30.000			29.376	.312 (.273)				XS	29.250	.375 (.328)	28.750	.625 (.547)			29.000	.500 (.438)
32	32.000			31.376	.312 (.273)				XS	31.250	.375 (.328)	30.750	.625 (.547)	30.624	.688 (.602)	31.000	.500 (.438)
34	34.000			33.376	.312 (.273)				XS	33.250	.375 (.328)	32.750	.625 (.547)	32.624	.688 (.602)	33.000	.500 (.438)
36	36.000			35.376	.312 (.273)				XS	35.250	.375 (.328)	34.750	.625 (.547)	34.500	.750 (.656)	35.000	.500 (.438)
38	38.000									37.250	.375 (.328)						.500 (.438)
40	40.000									39.250	.375 (.328)						.500 (.438)
42	42.000									41.250	.375 (.328)	40.750	.625 (.547)	40.500		41.000	.500 (.438)
44	44.000									43.250	.375 (.328)					43.000	.500 (.438)
46	46.000									45.250	.375 (.328)					45.000	.500 (.438)
48	48.000									47.250	.375 (.328)					47.000	.500 (.438)

## ANSI B36.10 API Std. 5L

Nominal Wall Thicknesses For All Schedules (with -12.5% values) Number in ( ) in Wall Thickness Column is Minimum Wall.

Nom. Size	Sch. 80		Sch. 100		Sch. 120		Sch. 140		Sch. 160		XS		API		
	ID	Wall	ID	Wall	ID	Wall	ID	Wall	ID	Wall	ID	Wall	ID	Wall	
1/8		XS													
1/4		XS													
3/8		XS													
1/2		XS							.464	.188 (.165)	.252	.294 (.257)			
3/4		XS							.612	.219 (.192)	.434	.308 (.280)			
1		XS							.815	.250 (.219)	.599	.358 (.313)			
1 1/4		XS							1.160	.250 (.219)	.896	.382 (.334)			
1 1/2		XS							1.338	.281 (.246)	1.100	.400 (.350)			
2		XS							1.687	.344 (.301)	1.503	.436 (.382)			
2 1/2		XS							2.125	.375 (.328)	1.771	.552 (.483)			
3		XS							2.624	.438 (.383)	2.300	.600 (.525)	3.250	.125 (.109)	
3 1/2		XS									2.728 <sup>1</sup>	.636 (.557) <sup>1</sup>			
4		XS			3.624	.438 (.383)			3.438	.531 (.465)	3.152	.674 (.590)	4.250	.125 (.109)	
5		XS			4.563	.500 (.438)			4.313	.625 (.547)	4.063	.750 (.656)			
6		XS			5.501	.562 (.492)			5.187	.719 (.629)	4.897	.864 (.756)	63.313 <sup>2</sup>	.156 (.136)	
8		XS			7.187	.719 (.629)	7.001	.812 (.710)	6.813	.906 (.793)	6.675	.875 (.766)	8.281 <sup>1</sup>	.172 (.150)	
10		XS	7.437	.594 (.520)	9.312	.719 (.629)	8.750	1.000 (.875)	8.500	1.125 (.984)		SCH 140	10.374	.188 (.164)	
12		XS	9.562	.594 (.520)	11.062	.844 (.738)	10.750	1.000 (.875)	10.500	1.125 (.984)	10.126	1.312 (1.148)	SCH 120	12.344	.203 (.178)
14		XS	11.374	.688 (.602)	12.124	.938 (.821)	11.812	1.094 (.957)	11.500	1.250 (1.094)	11.188	1.406 (1.230)			
16		XS	14.312	.844 (.739)	13.938	1.031 (.902)	13.562	1.219 (1.067)	13.124	1.438 (1.256)	12.812	1.594 (1.395)			
18		XS	16.124	.938 (.821)	15.688	1.156 (1.012)	15.250	1.375 (1.203)	14.876	1.562 (1.367)	14.438	1.781 (1.558)			
20		XS	17.938	1.031 (.902)	17.438	1.281 (1.121)	17.000	1.500 (1.312)	16.500	1.750 (1.531)	16.062	1.969 (1.723)			
22		XS	19.750	1.125 (.984)	19.250	1.375 (1.203)	18.750	1.625 (1.422)	18.250	1.875 (1.641)	17.750	2.125 (1.859)			
24		XS	21.562	1.219 (1.067)	20.938	1.531 (1.340)	20.376	1.812 (1.586)	19.876	2.062 (1.804)	19.312	2.344 (2.051)			
26															
28															
30															
32															
34															
36															
38															
40															
42															
44															
46															
48															

<sup>1</sup> Not in ANSI B36.10  
<sup>2</sup> Not in API

These Spaces have been provided so that new pipe size can be included as they become available

# Decimal & Metric Equivalents to Fractions API vs Flange Dimensions

## Decimal & Metric Equivalents to Fractions

Fractions		DECIMAL	MM
	1/64	.01562	0.397
1/32		.03125	0.794
	3/64	.04687	1.191
1/16		.0625	1.588
	5/64	.07812	1.984
3/32		.09375	2.381
	7/64	.10937	2.778
1/8		.1250	3.175
	9/64	.14062	3.572
5/32		.15625	3.969
	11/64	.17187	4.366
3/16		.1875	4.763
	13/64	.20312	5.159
7/32		.21875	5.556
	15/64	.23437	5.953
1/4		.2500	6.350
	17/64	.26562	6.747
9/32		.28125	7.144
	19/64	.29687	7.541
5/16		.3125	7.938
	21/64	.32812	8.334
11/32		.34375	8.731
	23/64	.35937	9.128
3/8		.3750	9.525
	25/64	.39062	9.922
13/32		.40625	10.319
	27/64	.42187	10.716
7/16		.4375	11.113
	29/64	.45312	11.509
15/32		.46875	11.906
	31/64	.48437	12.303
1/2		.5000	12.700
	33/64	.51562	13.097
17/32		.53125	13.494
	35/64	.54687	13.891
9/16		.5625	14.288
	37/64	.57812	14.684
19/32		.59375	15.081
	39/64	.60937	15.478
5/8		.6250	15.875
	41/64	.64062	16.272
21/32		.65625	16.669
	43/64	.67187	17.066
11/16		.6875	17.463
	45/64	.70312	17.859
23/32		.71875	18.256
	47/64	.73437	18.653
3/4		.7500	19.050
	49/64	.76562	19.447
25/32		.78125	19.844
	51/64	.79687	20.241
13/16		.8125	20.638
	53/64	.82812	21.034
27/32		.84375	21.431
	55/64	.85937	21.828
7/8		.8750	22.225
	57/64	.89062	22.622
29/32		.90625	23.019
	59/64	.92187	23.416
15/16		.9375	23.812
	61/64	.95312	24.209
31/32		.96875	24.606
	63/64	.98437	25.003
1		1.0000	25.400

## API vs ANSI Flange Dimensions

Flange Type	Pressure Class Designation		Nominal Size Range	
	ANSI	API	ANSI	API
Welding Neck	600	2000	1/2 - 10	1 13/16 - 11
	900	3000	1/2 - 10	1 13/16 - 11
	1500	5000	1/2 - 10	1 13/16 - 11
Blind, Threaded, & Integral <sup>1</sup>	600	2000	1/2 - 20	1 13/16 - 21 1/4
	900	3000	1/2 - 20	1 13/16 - 20 3/4
	1500	5000	1/2 - 20	1 13/16 - 11

# Forged Steel





# Threaded Fittings— Class 2000, 3000 & 6000

### DIMENSIONS (Inches)

Class 2000	NOMINAL PIPE SIZE	1/8	1/4	3/8	1/2	3/4	1	1 1/4	1 1/2	2	2 1/2	3	4
	A		7/8	3/2	1 1/8	1 1/4	1 1/2	1 3/4	2	2 3/8	2 1/2	3 1/4	3 3/8
B		2 3/2	1 1/4	1 1/2	1 3/4	2	2 1/2	2 3/4	3 1/2	3 3/4	4 1/2	5 1/4	
F		3/4	1	1 1/8	1 1/4	1 1/2	1 3/4	2	2 1/4	2 3/8	2 1/2	3 1/8	3 3/8

Class 3000	A	7/8	3/2	1 1/8	1 1/4	1 1/2	1 3/4	2	2 3/8	2 1/2	3 1/4	3 3/8	4 1/2
	B	2 3/2	1 1/4	1 1/2	1 3/4	2	2 1/2	2 3/4	3 1/2	3 3/4	4	4 3/4	6
	F	3/4	1	1 1/8	1 1/4	1 1/2	1 3/4	2	2 1/4	2 3/8	2 1/2	3 1/8	3 3/8
	H	1 1/4	1 1/2	1 3/8	1 1/2	1 3/4	2	2 1/4	2 3/8	2 1/2	3 1/4	3 3/8	4 1/2
Class 6000	J	7/8	1	1 1/8	1 1/4	1 1/2	1 3/4	2	2 1/4	2 1/2			
	K	1 7/8	2 1/8	2 3/8	3	3 1/2	3 3/4	4 1/4	5				
	L	2 1/4	3	3 3/8	4 1/8	4 3/4	5 3/8	6 1/4	6 3/8				

Class 6000	A	3/2	1 3/8	1 1/2	1 3/4	2	2 3/8	2 1/2	3 1/4	3 3/8	4 1/2	4 3/4	6
	B	1 1/4	1 3/8	1 1/2	1 3/4	2	2 1/4	2 3/8	2 1/2	3 1/4	3 3/8	4 1/2	4 3/4
	F	3/4	1	1 1/8	1 1/4	1 1/2	1 3/4	2	2 1/4	2 3/8	2 1/2	3 1/8	3 3/8
	H	1 1/4	1 1/2	1 3/8	1 1/2	1 3/4	2	2 1/4	2 3/8	2 1/2	3 1/4	3 3/8	4 1/2
Class 6000	J	7/8	1	1 1/8	1 1/4	1 1/2	1 3/4	2	2 1/4	2 1/2			
	K			2 3/8	3	3 1/2	3 3/4	4 1/4	5				
	L			3 3/8	4 1/8	4 3/4	5 3/8	6 1/4	6 3/8				

### WEIGHTS (Pounds)

Class 2000	90° ELBOW	.25	.198	.283	.500	.773	1.013	1.550	2.180	3.140	6.50	10.925	26.675
	45° ELBOW	.125	.188	.236	.435	.740	1.058	1.375	1.740	2.883	7.75	11.313	19.125
	TEE	.25	.267	.373	.613	.963	1.355	2.030	2.800	4.456	9.530	12.908	28.700
	CROSS	.50	.50	.460	.777	1.125	1.688	2.450	3.188	5.560	16.438	19.50	32.688
Class 3000	90° ELBOW	.236	.350	.592	.973	1.355	2.265	2.407	3.50	5.920	11.900	14.438	31.975
	45° ELBOW	.25	.290	.50	.75	1.188	1.988	2.235	3.00	4.930	7.375	13.558	19.063
	TEE	.325	.460	.753	1.270	1.830	3.025	3.620	7.040	7.550	13.125	23.100	40.000
	STREET ELBOW	.264	.242	.375	.595	1.048	1.438	2.340	3.00	5.461			
Class 6000	LATERAL		.625	1.313	1.75	2.75	4.625	5.50	10.813				
	CROSS	.438	.567	.970	1.50	2.50	3.620	4.125	6.50	8.125	16.75	25.675	32
	90° ELBOW	.25	.625	1.023	1.625	2.625	3.50	6.75	7.50	13.438	20.875	39.050	38
	45° ELBOW	.25	.640	.50	1.438	2.188	2.785	4.688	5.75	9.50	15	30.563	29
Class 6000	TEE	.50	.853	1.410	2.150	3.563	4.625	7.625	9.625	18.500	28.063	47.500	50
	STREET ELBOW		.375	.438	1	1.625	3.030	3.688	7.120				
	LATERAL			2.375	3.25	5.438	7.188	12.313					
	CROSS	.563	1.188	1.50	2.75	4.313	6.625	10.75	11.50	22.188	27.50	54	43.50

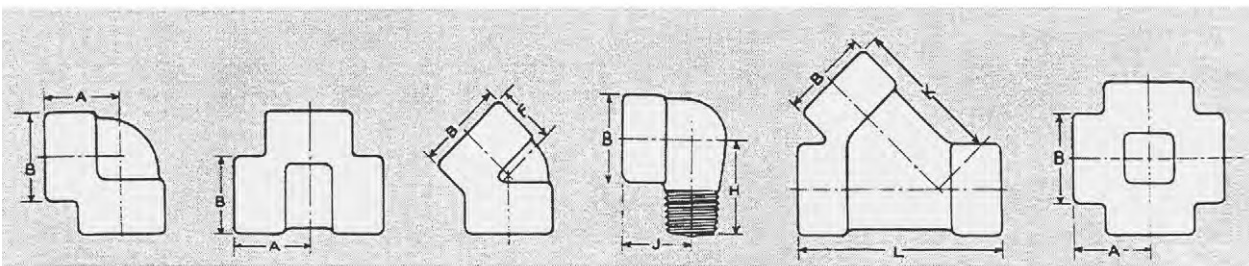

### DIMENSIONS (Inches)

Class 3000	NOMINAL PIPE SIZE	1/8	1/4	3/8	1/2	3/4	1	1 1/4	1 1/2	2	2 1/2	3	4
	A	1 1/4	1 3/8	1 1/2	1 7/8	2	2 3/8	2 5/8	3 1/8	3 3/8	3 5/8	4 1/4	4 3/4
B	3/4	3/4	7/8	1 1/8	1 3/8	1 3/4	2 1/4	2 1/2	3	3 5/8	4 1/4	5 1/2	
C	5/8	1 1/16	3/4	1 1/16	1	1 3/16	1 5/16	1 7/16	1 11/16	1 13/16	2 1/8	2 3/8	
D	1 1/16	1	1	1 1/4	1 1/16	1 5/8	1 3/4	1 3/4	1 7/8	2 3/8	2 7/16	2 11/16	

Class 6000	A	1 1/4	1 3/8	1 1/2	1 7/8	2	2 3/8	2 5/8	3 1/8	3 3/8	3 5/8	4 1/4	4 3/4
	B	7/8	1	1 1/4	1 1/2	1 3/4	2 1/4	2 1/2	3	3 5/8	4 1/4	5	6 1/4
	C	5/8	1 1/16	3/4	1 1/16	1	1 3/16	1 5/16	1 7/16	1 11/16	1 13/16	2 1/8	2 3/8
	D	1	1 1/16	1 1/16	1 1/16	1 1/2	1 11/16	1 13/16	1 7/8	2	2 1/2	2 11/16	2 5/16

### WEIGHTS (Pounds)

Class 3000	COUPLING	.125	.125	.25	.25	.438	.625	1.563	2.188	3.125	4	6.75	16.75
	REDUCER	.125	.125	.25	.25	.438	.625	1.563	2.188	3.125	4	6.75	16.75
	HALF COUPLING	.063	.063	.188	.188	.25	.313	.75	1.125	1.563	2	3.375	8.375
	PIPE CAP	.031	.063	.125	.25	.313	.50	1	1.625	3.125	5	8.50	14

Class 6000	COUPLING	.188	.188	.25	.50	1	2.125	2.375	4.375	7.75	10.75	13.50	24.50
	REDUCER	.188	.188	.25	.50	1	2.125	2.375	4.375	7.75	10.75	13.50	24.50
	HALF COUPLING	.094	.094	.125	.25	.50	1.063	1.188	2.188	3.875	5.375	6.75	12.25
	PIPE CAP	.125	.125	.188	.313	.438	.75	1.313	1.688	3.25			

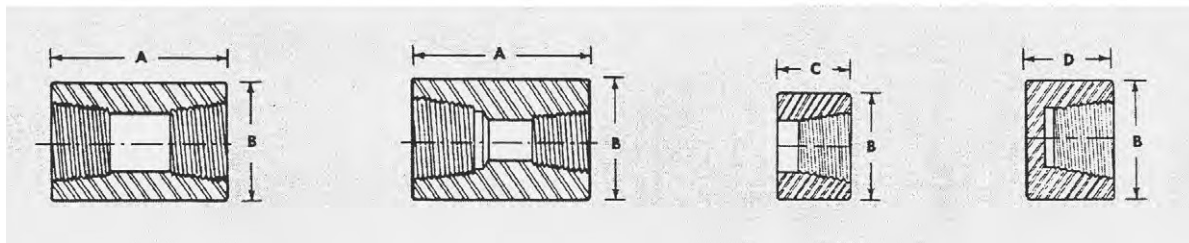



### DIMENSIONS (Inches)

NOMINAL PIPE SIZE	1/8	1/4	3/8	1/2	3/4	1	1 1/4	1 1/2	2	2 1/2	3	4
A	1 3/8	1 5/8	1 5/8	1 3/4	1 3/4	2	2	2	2 1/2	2 3/4	2 3/4	3
B	1 3/32	1 1/32	1 1/16	2 1/32	1 1/16	1 3/16	1 11/16	1 29/32	2 3/8	2 7/8	3 1/2	4 1/2
C*	7/16	5/8	1 1/16	7/8	1 1/16	1 7/16	1 13/16	2	2 1/2	3	3 3/4	4 5/8
D	1/4	1/4	5/16	5/16	3/8	3/8	5/16	5/8	1 1/16	3/4	1 1/16	1 1/4
E	7/16	1/2	5/16	1 1/16	3/4	2 1/32	7/8	1 5/16	1	1 1/4	1 5/16	1 21/32
F	5/32	3/8	7/16	5/16	5/8	1 3/16	1 5/16	1 1/8	1 5/16	1 1/2	1 11/16	2 1/2
G	1/4	1/4	5/16	3/8	7/16	1/2	5/16	5/8	1 1/16	3/4	1 3/16	1 1/4
H	3/8	7/16	1/2	5/16	5/8	3/4	1 3/16	1 3/16	7/8	1 1/16	1 1/8	1 3/8
J*		5/8	1 1/16	7/8	1 1/16	1 7/16	1 13/16	2	2 1/2	3	3 3/4	4 5/8
K		3/16	3/16	3/16	1/4	1/4	3/8	3/8	3/8	1/2	13/16	1 1/4
L		1/2	5/16	1 1/16	3/4	2 1/32	7/8	1 5/16	1	1 1/4	1 5/16	1 21/32
M		7/16	1/2	5/16	5/8	3/4	1 3/16	1 3/16	7/8	1 1/16	1 1/8	1 1/4
N	3/8	7/16	1/2	5/16	5/8	3/4	1 3/16	1 3/16	7/8	1 1/16	1 1/8	1 1/4

### WEIGHTS (Pounds)

ROUND HEAD PLUGS	.125	.125	.188	.250	.375	.750	1.125	1.563	3.00	4.75	7.62	12.87
HEXAGON PLUGS	.063	.063	.125	.188	.313	.500	1.125	1.375	2.25	3.87	5.87	13.00
SQUARE HEAD PLUGS	.016	.031	.063	.125	.188	.313	.563	.875	1.50	2.25	2.87	7.18
HEXAGON BUSHINGS		.063	.063	.063	.125	.188	.375	.688	1.62	2.37	3.50	8.31
FLUSH BUSHINGS		.063	.063	.063	.125	.125	.125	.188	.37	.62	1.00	2.00

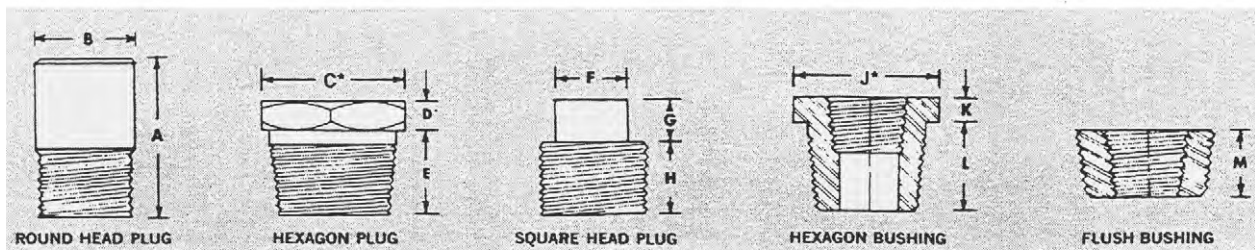

\*Dimension J for Hex Head Bushing and dimension C for Hex Head Plug are the same.



### DIMENSIONS (Inches)

Class 3000 Schedule 40 Bore	NOMINAL PIPE SIZE	1/8	1/4	3/8	1/2	3/4	1	1 1/4	1 1/2	2	2 1/2	3	4
	A	7/8	3/4	1 1/2	1 1/2	1 1/2	1 1/2	1 1/2	1 3/4	2	2 3/8	3	3 3/8
B	2 1/2	2 1/2	1 1/4	1 1/4	1 1/4	1 1/4	1 1/2	2 1/2	2 1/2	3 1/2	3 11/16	4 1/4	5 1/4
D	7/8	7/8	7/8	1 1/2	1 1/2	1 1/2	1 1/2	1 1/2	2 1/2	2 1/2	3 1/8	3 1/8	4 1/8
E	7/8	7/8	1 1/2	3/8	3/4	3/4	7/8	1 1/4	1 1/4	1 1/2	1 1/2	2 1/4	2 3/8
F	3/4	3/4	3/4	1	1 1/4	1 1/4	1 1/4	1 1/4	1 3/8	1 3/8	2 1/8	2 1/2	3 1/8
G	3/8	3/8	3/8	3/8	1/2	1/2	3/8	1 1/8	1 1/8	1	1	1 1/4	1 3/8
H	1 1/4	1 1/4	1 1/4	1 1/4	1 1/4	1 1/4	2 1/4	2 1/4	2 3/8	3 1/8	3 1/8		
J	3/8	3/8	1	1 1/4	1 1/4	1 1/4	1 1/4	2	2 1/4	2 1/4			
K			1 1/4	2 1/8	2 1/8	2 1/8	3	3 1/2	3 1/2	4 3/4			
L			2 1/4	3	3 1/4	3 1/4	4 1/8	4 1/8	5 1/8	6 1/8			

Class 6000 Schedule 160 Bore	NOMINAL PIPE SIZE	1/8	1/4	3/8	1/2	3/4	1	1 1/4	1 1/2	2	2 1/2	3	4
	A	7/8	3 1/2	1 1/4	1 1/4	1 1/2	1 1/2	1 3/4	2	2 3/8	2 1/2	3 1/4	3 3/4
B	2 1/2	1 1/4	1 1/4	1 1/4	1 1/4	1 1/2	2 1/2	2 1/2	3 1/2	3 1/2	4	4 3/4	6
D	7/8	7/8	1 1/2	1 1/2	1 1/2	1 1/2	1 1/2	1 1/2	2 1/2	2 1/2	3 1/8	3 1/8	4 1/8
E	7/8	1 1/2	3/8	3/4	3/4	3/4	1 1/4	1 1/4	1 1/2	1 3/8	2 1/4	2 1/2	2 3/4
F	3/4	3/4	1	1 1/4	1 1/4	1 1/4	1 1/4	1 3/8	1 3/8	1 3/8	2 1/8	2 1/2	3 1/8
G	3/8	3/8	3/8	1/2	1/2	1/2	3/8	1 1/8	1 1/8	1	1 1/4	1 3/8	1 3/8
H	1 1/4	1 1/4	1 1/4	1 1/4	1 1/4	1 1/4	2 1/4	2 1/4	2 3/8	3 1/8			
J	3/8	1	1 1/4	1 1/4	1 1/4	1 1/4	2	2 1/4	2 1/4	2 1/4			
K			2 1/8	2 3/8	2 3/8	3	3 1/2	3 1/2	4 3/4				
L			3	3 1/4	3 1/4	4 1/8	4 1/8	5 1/8	6 1/8				

### WEIGHTS (Pounds)

Class 3000	Dimensions C (Common to all fittings)	.420	.555	.690	.855	1.065	1.330	1.675	1.915	2.406	2.906	3.535	4.545
	90° ELBOW		.125	.183	.270	.460	.698	.987	1.480	2.088	3.125	6.340	10.867
45° ELBOW		.125	.198	.210	.440	.673	.935	1.365	1.63	2.71	6.75	10.50	18.188
TEE		.25	.25	.345	.540	.925	1.307	2.00	2.640	4.070	8.75	12.50	27.80
STREET ELBOW		.25	.25	.375	.50	.875	1.438	2.25	3.00	5.188			
LATERAL			.25	.625	1.00	1.500	2.375	3.75	4.125	6.285			
CROSS		.25	.25	.375	.813	1.125	1.550	2.25	3.063	5.125	18.00	23.00	40.00
Class 6000	90° ELBOW				.938	1.440	2.348	3.188	5.25	6.660	11.875	19.25	32.70
	45° ELBOW				.875	1.313	1.913	2.27	4.313	4.813	9.625	14.25	27.25
	TEE				1.375	2.00	3.313	3.75	7.480	8.240	16.625	23.50	33.00
	STREET ELBOW		.375	.438	1.00	1.625	2.50	3.688	6.438				
	LATERAL				2.00	3.063	5.125	6.25	11.938				
	CROSS				1.50	2.50	3.460	5.25	8.75	9.438	20.25	27.00	39.00

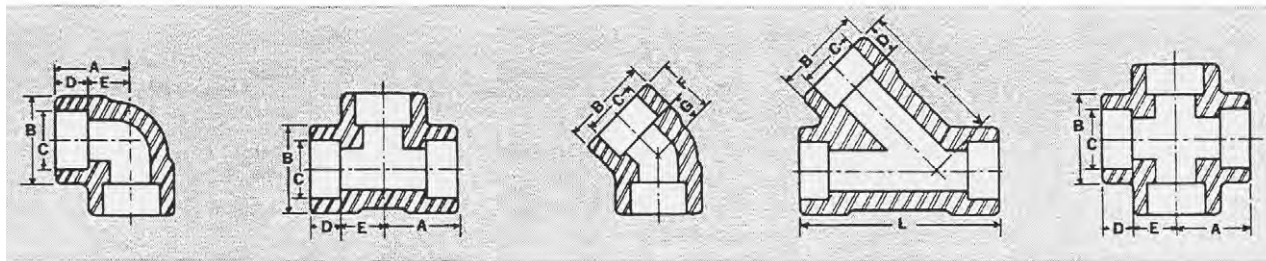

### DIMENSIONS (Inches)

Class 3000	NOMINAL PIPE SIZE	1/8	1/4	3/8	1/2	3/4	1	1 1/4	1 1/2	2	2 1/2	3	4
	A	1 1/8	1 1/8	1 1/8	1 3/8	1 1/2	1 3/4	1 7/8	2	2 1/2	2 1/2	2 3/4	3
B	3/4	7/8	1 1/16	1 1/4	1 1/2	1 5/16	2 1/4	2 1/2	3	3 5/8	4 1/16	5 1/2	
C	.420	.555	.690	.855	1.065	1.330	1.675	1.915	2.406	2.906	3.535	4.545	
D	7/16	7/16	7/16	1/2	5/16	5/8	1 1/16	3/4	7/8	7/8	1	1 1/8	
E	1/4	1/4	1/4	3/8	3/8	1/2	1/2	1/2	3/4	3/4	3/4	3/4	
F	1 1/16	3/4	3/4	7/8	1	1 1/16	1 3/16	1 1/4	1 1/2	1 9/16	1 13/16	2 1/16	

Class 6000	A	1 1/8	1 1/8	1 3/8	1 1/2	1 3/4	1 7/8	2	2 1/2	2 1/2	2 3/4	3
	B	1 1/16	1 5/16	1 1/2	1 3/4	2 1/4	2 1/2	3	3 5/8	4 1/4	5	6 1/4
C	.555	.690	.855	1.065	1.330	1.675	1.915	2.406	2.906	3.535	4.545	
D	7/16	7/16	1/2	5/16	5/8	1 1/16	3/4	7/8	7/8	1	1 1/8	
E	1/4	1/4	3/8	3/8	1/2	1/2	1/2	3/4	3/4	3/4	3/4	
F	1 1/16	1 1/16	1	1 1/16	1 1/4	1 5/16	1 3/8	1 5/8	1 11/16	1 15/16	2 5/16	

### WEIGHTS (Pounds)

Class 3000	COUPLING	.125	.125	.125	.188	.313	.563	.813	1	2	2.625	3.875	6.625
	REDUCER	.125	.125	.125	.188	.313	.563	.813	1	2	2.625	3.875	6.625
	HALF COUPLING	.125	.125	.125	.188	.313	.563	.813	1	2	2.625	3.875	6.625
	PIPE CAP	.063	.063	.125	.188	.313	.375	.813	1.125	1.688	3	3.625	6.688

Class 6000	COUPLING				.375	.563	1	1.438	2	3.875	5.50	6.625	13.125
	REDUCER				.375	.563	1	1.438	2	3.875	5.50	6.625	13.125
	HALF COUPLING				.375	.563	1	1.438	2	3.875	5.50	6.625	13.125
	PIPE CAP				.375	.50	1.125	1.125	2.25	3.50	5.625	6	13.50

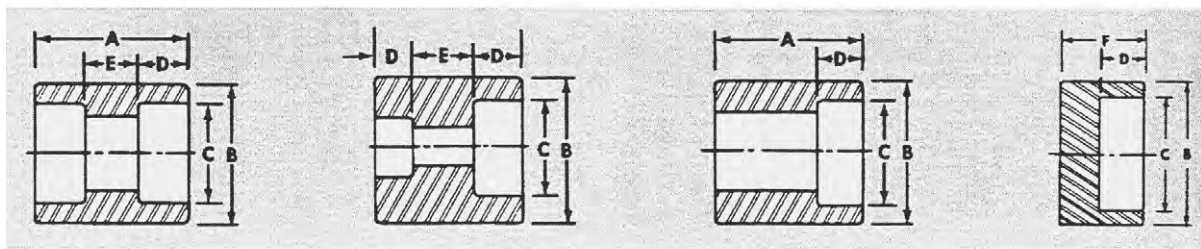

# Socket Weld Reducer Inserts— Class 3000, 6000 & 9000

NOMINAL PIPE SIZE	C	D	Class *3000				Class *6000				Class *9000			
			FTG. TYPE	A	B	E	FTG. TYPE	A	B	E	FTG. TYPE	A	B	E
3/8 x 1/4	.675	.555	1	7/16	3/4	15/16	1	7/16	7/8	1				
1/2 x 3/8	.850	.690	1	7/16	13/16	11/16	1	7/16	15/16	1 3/16				
1/2 x 1/4	.850	.555	1	7/16	13/16	15/16	1	7/16	7/8	1				
3/4 x 1/2	1.060	.855	1	7/16	7/8	15/16	1	7/16	11/16	13/8	1	7/16	13/16	13/4
3/4 x 3/8	1.060	.690	2	7/16	5/8	—	1	7/16	7/8	13/16				
3/4 x 1/4	1.060	.555	2	3/8	11/16	—	2	3/8	7/8	—				
1 x 3/4	1.325	1.065	1	9/16	15/16	1 1/2	1	9/16	1 1/8	1 11/16	1	9/16	1 1/4	2
1 x 1/2	1.325	.855	2	1/2	5/8	—	1	7/16	1 1/8	13/8	1	7/16	1 1/8	13/4
1 x 3/8	1.325	.690	2	7/16	11/16	—	2	1/2	7/8	—				
1 x 1/4	1.325	.555	2	3/8	3/4	—	2	3/8	15/16	—				
1 1/4 x 1	1.670	1.330	1	9/16	1	1 7/8	1	9/16	13/16	2	1	9/16	13/8	2 3/8
1 1/4 x 3/4	1.670	1.065	2	9/16	11/16	—	2	9/16	13/16	—	1	9/16	13/16	2
1 1/4 x 1/2	1.670	.855	2	1/2	3/4	—	2	1/2	7/8	—	2	1/2	7/8	—
1 1/4 x 3/8	1.670	.690	2	7/16	13/16	—	2	7/16	15/16	—				
1 1/4 x 1/4	1.670	.555	2	3/8	7/8	—	2	3/8	1	—				
1 1/2 x 1 1/4	1.910	1.675	1	9/16	1 1/8	2 1/4	1	9/16	13/8	2 3/8	1	9/16	15/8	2 3/4
1 1/2 x 1	1.910	1.330	2	5/8	1 1/16	—	1	9/16	13/16	2	1	9/16	13/8	2 3/8
1 1/2 x 3/4	1.910	1.065	2	9/16	3/4	—	2	9/16	1	—	2	9/16	1	—
1 1/2 x 1/2	1.910	.855	2	1/2	13/16	—	2	1/2	1 1/16	—	2	9/16	1	—
1 1/2 x 3/8	1.910	.690	2	7/16	7/8	—	2	7/16	1 1/8	—				
2 x 1 1/2	2.385	1.915	1	9/16	1 1/4	2 1/2	1	9/16	1 7/8	2 11/16	1	9/16	2 1/16	3
2 x 1 1/4	2.385	1.675	2	11/16	13/16	—	2	7/8	15/16	—	1	9/16	2	2 3/4
2 x 1	2.385	1.330	2	5/8	7/8	—	2	13/16	1	—	2	13/16	1	—
2 x 3/4	2.385	1.065	2	9/16	15/16	—	2	3/4	1 1/16	—	2	3/4	1 1/16	—
2 x 1/2	2.385	.855	2	1/2	1	—	2	1 1/16	1 1/8	—	2	1 1/16	1 1/8	—

Note: Socket weld reducer inserts comply fully with MSS-SP-79

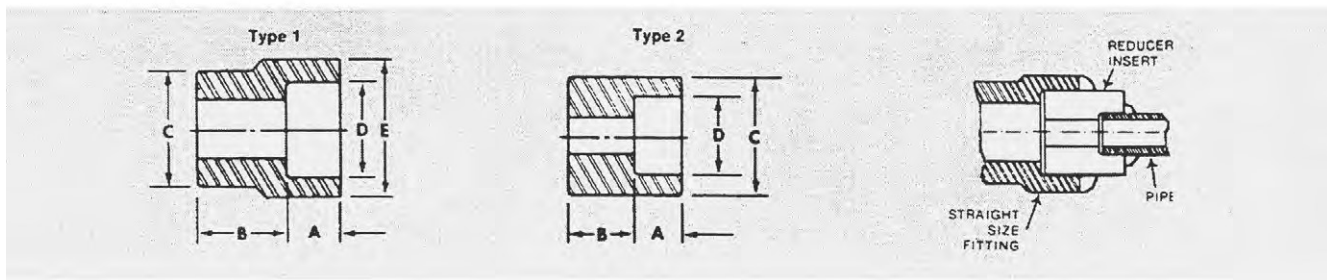

# MSS-SP\_83 Unions (formerly AAR Unions) Threaded & Socket Weld

CLASS 3000							
PIPE SIZE	A	B	C	D	E	F	WEIGHT PER UNION
1/8	1 1/16	1 3/16	5/8	2 5/32	7/16	.420 .430	.38 #
1/4	1 1/8	1 3/8	5/8	2 5/32	7/16	.555 .565	.36 #
3/8	1 7/32	1 1/2	1	2 1/2	7/16	.690 .700	.50 #
1/2	2	1 5/8	1 1/8	2 1/2	7/16	.855 .865	.695#
3/4	2 1/8	2 3/8	1 1/2	2 1/2	7/16	1.065 1.075	1.175#
1	2 1/4	2 5/8	1 3/4	2 1/2	7/16	1.330 1.340	1.64 #
1 1/4	2 3/4	3 1/4	2 1/2	2 1/2	7/16	1.675 1.685	2.59 #
1 1/2	3	3 3/4	2 3/4	2 1/2	7/16	1.915 1.925	3.41 #
2	3 1/2	4 1/4	3 1/8	2 1/2	1 1/16	2.406 2.416	5.12 #
2 1/2	4 1/4	5 1/4	3 3/8	2 3/8	7/8	2.906 2.921	8.75 #
3	4 7/8	6 1/2	4 1/2	2 7/8	1	3.535 3.550	12.625#

CLASS 6000							
PIPE SIZE	A	B	C	D	E	F	WEIGHT PER UNION
1/8	1 1/4	1 3/4	5/8	2 5/32	7/16	.420 .430	.5 #
1/4	1 7/32	1 1/2	1	2 1/2	7/16	.555 .565	.56#
3/8	2	1 5/8	1 1/8	2 1/2	7/16	.690 .700	.75#
1/2	2 1/8	2 3/8	1 1/2	2 1/2	7/16	.855 .865	1.25#
3/4	2 3/8	2 5/8	1 3/4	2 1/2	7/16	1.065 1.075	1.75#
1	2 1/2	3 1/4	2 1/2	2 1/2	7/16	1.330 1.340	3 #
1 1/4	3	3 3/4	2 3/4	2 1/2	7/16	1.675 1.685	3.75#
1 1/2	3 1/2	4 1/4	3 1/8	2 1/2	1 1/16	1.915 1.925	6.0 #
2	4 1/8	5 1/4	3 3/8	2 3/8	7/8	2.406 2.416	10.5 #

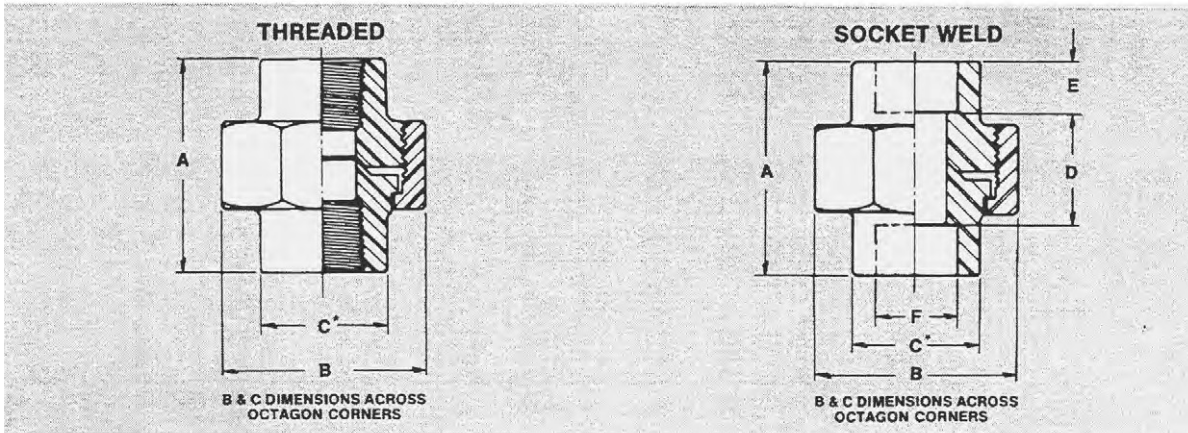

\*"C" dimension is across octagon corners or a diameter as applicable. The 2 1/2" and 3" 3000 and 2" 6000 sizes have octagonal male and female ends; the other sizes are round.

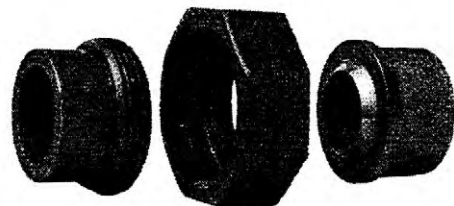

A large, empty rectangular box with a thin black border, occupying most of the page. It is intended for taking notes.

# Olets







## FLEXOLET™ SA/A105

**BUTT WELDED**

**STANDARD WEIGHT**

**EXTRA STRONG**

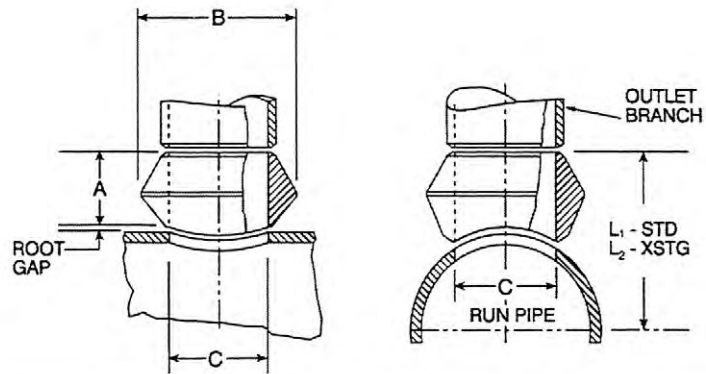

	Outlet Size Inches	Dimensions			Appx. Weight Pounds
		A	B	C	
<b>Standard</b>	3/8	3/4	1	0.493	0.10
	1/2	3/4	1-1/8	0.622	0.12
	3/4	7/8	1-1/2	0.824	0.22
	1	1-1/16	1-13/16	1.062	0.32
	1-1/4	1-1/4	2-1/4	1.38	0.64
	1-1/2	1-5/16	2-9/16	1.625	0.78
	2	1-1/2	3-5/16	2.313	1.14
	2-1/2	1-5/8	3-21/32	2.500	1.94
	3	1-3/4	4-9/32	3.125	2.60
	4	2	5-3/8	4.145	4.12
	6	2-3/8	7-21/32	6.112	11.00

	Outlet Size Inches	Dimensions			Appx. Weight Pounds
		A	B	C	
<b>Extra Strong</b>	3/8	3/4	1	0.423	0.10
	1/2	3/4	1-1/8	0.546	0.12
	3/4	7/8	1-1/2	0.742	0.18
	1	1-1/16	1-13/16	1.062	0.36
	1-1/4	1-1/4	2-1/4	1.278	0.55
	1-1/2	1-5/16	2-9/16	1.625	0.68
	2	1-1/2	3-5/16	2.313	1.24
	2-1/2	1-5/8	3-21/32	2.500	2.26
	3	1-3/4	4-9/32	3.125	2.84
	4	2	5-3/8	4.145	4.56
	6	3-1/16	7-23/32	5.800	15.00

Each outlet size listed is available to fit any run curvature.  
BW Ends per B16.9 and B16.25. Design per MSS-SP-97.

**SCHEDULES**

Standard Weight Fittings are the same as schedule 40 fittings through 10". A schedule 40 butt-welded Flexolet for sizes 12" and larger is available. Dimensions and prices on application.

Extra Strong Fittings are the same as schedule 80 fittings through 8". A schedule 80 butt-welded Flexolet for sizes 10" and larger is available. Dimensions and prices on application. Pipe schedule numbers and weight designations are in accordance with ASME B36.10.

**FLATS**

Flat butt-welded Flexolet fittings for use on welding caps, elliptical heads and 1 surfaces are available.



**FLEXOLET™**  
SA/A105 & SA/A350 LF2 CL1

**THREADED**  
**CL 3000**  
**CL 6000**

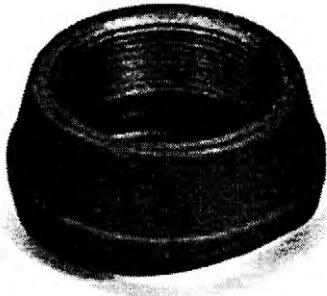
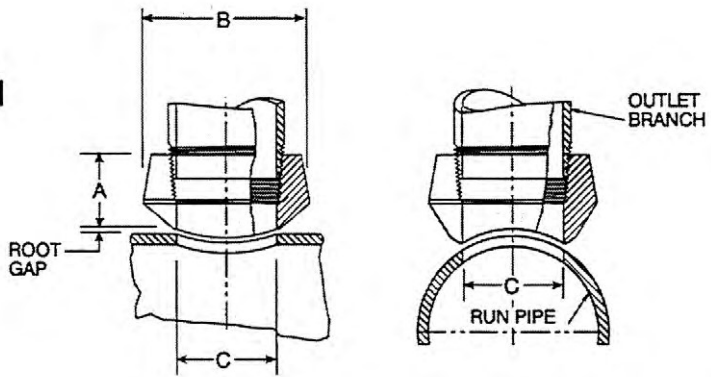

Outlet Size Inches	Dimensions			Appx. Weight Pounds
	A	B	C	
1/4	3/4	1-1/16	.437	0.14
3/8	13/16	1-1/16	.578	0.14
1/2	1	1-15/32	.718	0.28
3/4	1-1/16	1-45/64	.922	0.39
1	1-5/16	2-3/32	1.156	0.73
1-1/4	1-5/16	2-17/32	1.500	0.96
1-1/2	1-3/8	2-25/32	1.734	1.12
2	1-1/2	3-5/16	2.218	1.66
2-1/2	1-13/16	3-29/32	2.625	2.73
3	2	4-21/32	3.250	3.88
4	2-1/4	5-13/16	4.250	6.18

Outlet Size Inches	Dimensions			Appx. Weight Pounds
	A	B	C	
1/4	3/4	1-1/16	.437	0.14
3/8	1-1/8	1-5/16	.578	0.14
1/2	1-1/4	1-3/4	.718	0.28
3/4	1-7/16	2-1/16	.922	0.39
1	1-9/16	2-17/32	1.156	0.73
1-1/4	1-5/8	2-1/2	1.500	0.96
1-1/2	1-11/16	3-5/16	1.734	1.12
2	2-1/16	3-31/32	2.218	1.66

Each outlet size listed is available to fit any run curvature.  
Threaded ends are in accordance with ANSI/ASME B1.20.1  
Design per MSS-SP-97.

**FLATS** A flat Threaded Flexolet for use on welding caps, elliptical heads and flat surfaces is available.

## FLEXOLET™ SA/A105 & SA/A350 LF2 CL1

**SOCKET WELDED**

**CL 3000**

**CL 6000**

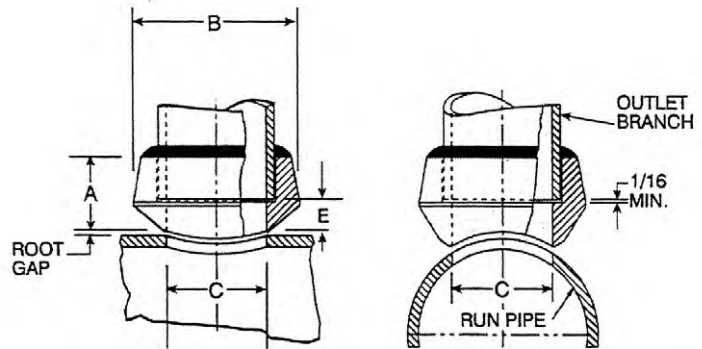

Outlet Size Inches	Dimensions				Appx. Weight Pounds
	A	B	C	E	
1/4	3/4	1	0.364	3/8	0.14
3/8	13/16	1-1/16	0.493	7/16	0.14
1/2	1	1-15/32	0.622	9/16	0.28
3/4	1-1/16	1-45/64	0.824	9/16	0.39
1	1-5/16	2-3/32	1.049	25/32	0.73
1-1/4	1-5/16	2-17/32	1.38	23/32	0.96
1-1/2	1-3/8	2-25/32	1.61	3/4	1.12
2	1-1/2	3-5/16	2.067	13/16	1.66
2-1/2	1-13/16	3-29/32	2.469	3/4	2.73
3	2	4-21/32	3.068	15/16	3.88
4	2-1/4	5-13/16	4.026	1-1/16	6.60

Outlet Size Inches	Dimensions				Appx. Weight Pounds
	A	B	C	E	
1/2	1-1/4	1-3/4	.464	13/16	0.28
3/4	1-7/16	2-1/16	.612	15/16	0.39
1	1-9/16	2-17/32	.815	1-1/32	0.73
1-1/4	1-5/8	2-1/2	1.16	1-1/32	0.96
1-1/2	1-11/16	3-5/16	1.338	1-1/16	1.63
2	2-1/16	3-31/32	1.687	1-3/8	1.66

Each outlet size listed is available to fit any run curvature.  
Socket dimensions are in accordance with ASME B16.11.  
Design per MSS-SP-97.

FLATS

A flat Socket-welded Flexolet for use on welding caps, elliptical heads and flat surfaces is available.



## LATROLET®

### 45° CONNECTIONS

### FORGED

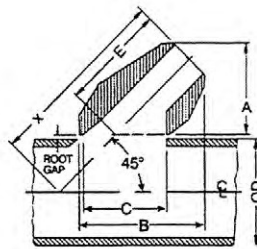

BUTT WELD

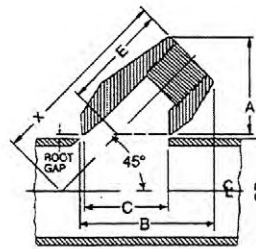

THREADED

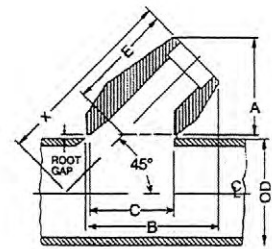

SOCKET-WELD

**45° BRANCH CONNECTIONS  
THREADED, SOCKET-WELD AND BUTT-WELD ENDS**

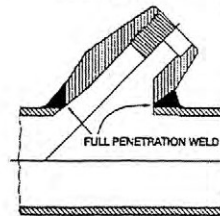

Nominal Run Pipe Size	Outlet Size	Dimensions																
		CL 3000 Threaded and Socket-Weld				CL 6000 Threaded and Socket-Weld				STD & XS Butt-Weld				Sch. 160 and XXS Butt-Weld				
		A	B	C	E	A	B	C	E	A	B	C	E	A	B	C		
2-1/2 12	-1-1/4 -3	1/4	1-9/16	2-11/32	1-7/16	1-9/16	1-9/16	2-11/32	1-7/16	1-9/16	1-5/16	2-3/32	1-7/16	1-9/16	1-9/16	2-5/16	1-7/16	
2-1/2 12	-1-1/4 -3	3/8	1-9/16	2-11/32	1-7/16	1-9/16	1-9/16	2-11/32	1-7/16	1-9/16	1-5/16	2-3/32	1-7/16	1-9/16	1-9/16	2-5/16	1-7/16	
2-1/2 12	-1-1/4 -3	1/2	1-9/16	2-11/32	1-7/16	1-9/16					1-3/8	2-5/32	1-7/16	1-9/16				
1-1/2 5 12	-1-1/4 -2 -6	1/2						1-7/8	2-3/4	1-3/4	1-29/32					1-13/16	2-3/4	1-3/4
1-1/2 5 12	-1-1/4 -2 -6	3/4	1-7/8	2-3/4	1-3/4	1-29/32					1-11/16	2-17/32	1-3/4	1-29/32				
2-1/2 5 12	-2 -3 -6	3/4						2-3/16	3-1/4	2-1/8	2-3/16					2-1/8	3-1/4	2-1/8
2-1/2 5 12	-2 -3 -6	1	2-3/16	3-1/4	2-1/8	2-3/16	2-1/2	3-21/32	2-5/8	2-15/32	1-31/32	3	2-1/8	2-3/16	2-1/2	3-13/16	2-5/8	
2-1/2 5 12	-2 -3 -6	1-1/4	2-1/2	3-27/32	2-5/8	2-15/16	2-3/4	4-7/32	3-1/32	2-5/8	2-9/32	3-19/32	2-5/8	2-15/32	2-3/4	4-1/4	3	
2-1/2 5 12	-2 -3 -6	1-1/2	2-3/4	4-7/32	3-1/32	2-5/8					2-15/32	3-31/32	3-1/32	2-5/8				
5 8 12	-4 -6 -10	1-1/2						3-3/8	5-7/16	4-1/8	3-5/32					3-3/8	5-3/8	4-1/8
5 8 12	-4 -6 -10	2	3-3/8	5-7/16	4-1/8	3-5/32	3-3/8	5-7/16	4-1/8	3-5/32	3-3/16	5-1/4	4-1/8	3-13/32				
5 8 12	-4 -6 -10	2-1/2									3-5/32	5-3/16	4-1/8	3-5/52				
Order to Specific Run Pipe Sizes	3										3-13/16	6-1/4	4-31/32	3-25/32				
	4										4-3/4	7-13/16	6-7/16	4-9/16				

## ELBOLET®

**90° LONG RADIUS  
FORGED**

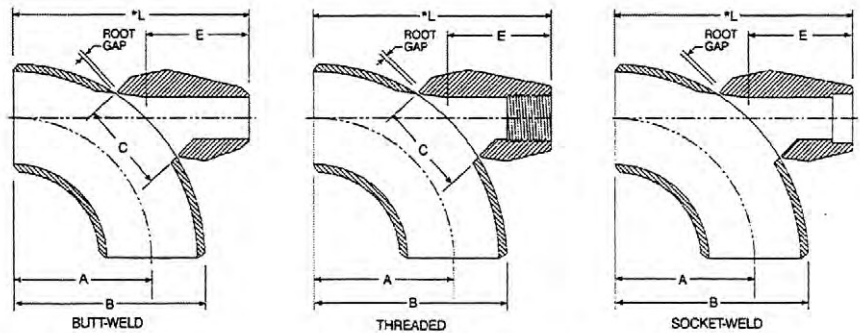

**FOR ELBOW OUTLETS  
THREADED, SOCKET-WELD AND BUTT-WELD ENDS**

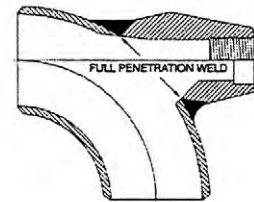

Nominal Elbow Size Inches	Outlet Size Inches	Dimensions			
		CL 3000 Threaded & Socket-Weld Std. & XS Butt-Weld		CL 6000 Threaded & Socket-Weld Sch. 160 & XXS Butt-Weld	
		C	E	C	E
36 - 3/4	1/4	1-1/2	1-19/32	1-1/2	1-19/32
36 - 3/4	3/8	1-1/2	1-19/32	1-1/2	1-19/32
36 - 3/4	1/2	1-1/2	1-19/32	1-23/32	1-7/8
36 - 1	3/4	1-23/32	1-7/8	2-1/4	2-1/4
36 - 2	1	2-1/4	2-1/4	2-7/8	2-1/2
36 - 2	1-1/4	2-7/8	2-1/2	3-1/8	2-11/16
36 - 2	1-1/2	3-1/8	2-11/16	4-3/16	3-1/4
36 - 3	2	4-3/16	3-1/4		
Order to Specific Elbow Sizes	**2-1/2	4-3/16	3-1/4	**	**
	**3	5-1/16	3-7/8		
	**4	6-5/8	4-13/16		
	**6	9-3/8	6-1/2		
	**8	13-5/16	8-1/16		
	**10	17-1/32	10-3/8		
	**12	19-5/8	11-1/8		

**Footnotes applying to the Elbolet and Latrolet:**

Socket Dimensions to ASME B16.11

Thread Dimensions to ANSI/ASME B1.20.1

Butt-welding End Dimensions to ASME B16.9 & B16.25

Each Elbolet 2" & smaller is uniquely designed to fit all the elbow sizes shown. The complete size range interchangeability is so marked on the fitting.

\*\*Available as Butt-Welding outlets only. Larger sizes available - STD/XS/S160/XXS.



## NIPOLET®

**FORGED**

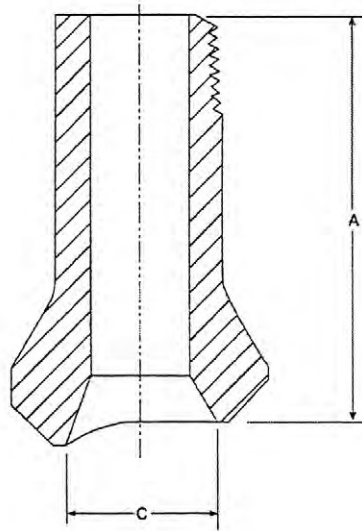

### A 1-PIECE FORGED FITTING THAT ELIMINATES THE NIPPLE, A COUPLING AND ONE WELD

It provides 100% reinforcement, improved flow characteristics and better distribution of stresses. The Bonney Forge Nipolet® is a superior, engineered branch connection at far less cost than the coupling and nipple connection.

		Plain End and Threaded						
		Size	1/2"	3/4"	1"	1-1/4"	1-1/2"	2"
XS	A	3-1/2	3-1/2	3-1/2	3-1/2	3-1/2	3-1/2	3-1/2
	C	15/16	1-3/16	1-7/16	1-3/4	2	2-9/16	
XXS	A	3-1/2	3-1/2	3-1/2	3-1/2	3-1/2	3-1/2	3-1/2
	C	9/16	3/4	1	1-5/16	1-1/2	1-11/16	

- Threaded or plain end (male socket weld)
- Available in outlet sizes 1/2" thru 2"

XS and XXS ratings represent the schedule of the nipple portion of the Nipolet® fitting.

## ENGINEERING SPECIFICATIONS

### FLEXOLET™ RUN SIZE COMBINATIONS

#### FLEXOLET™ SA/A105 & SA/350 LF2 CL1

	Outlet Size Inches											
	1/4	3/8	1/2	3/4	1	1 1/4	1 1/2	2	2 1/2	3	4	6
Butt-Weld, Steel	1/4	1/2-3/8	1-1/2	2-3/4	1	1 1/4	1 1/2	2	2 1/2	3	4	6
	36-3/8	36-3/4	36-1 1/4	36-2 1/2	1 1/2-1 1/4	2-1 1/2	3 1/2-2	3-2 1/2	4-3	6-5	10-8	14-12
Butt-Weld, XS	1/4	3/8	1/2	3/4	1	1 1/4	1 1/2	2	2 1/2	3	4	6
	36-1/4	36-1/2	36-1	1 1/2-3/4	1 1/2-1 1/4	2-1 1/4	3 1/2-2	3-2 1/2	4-3	6-5	10-8	14-12

Class 3000 Threaded	1/4	3/8	1/2	3/4	1	1 1/4	1 1/2	2	2 1/2	3	4
	3/8-1/4	1-3/8	1/2	1 1/4-3/4	1	1 1/2-1 1/4	1 1/2	2	2 1/2	3	4
Class 6000 Threaded	1/4	3/8	1/2	3/4	1	1 1/4	1 1/2	2	2 1/2	3	4
	3/8-1/4	1-3/8	1/2	1 1/4-1	1 1/2-1 1/4	2 1/2-2	2 1/2-2	3 1/2-2 1/2	3 1/2-3	5-3 1/2	6-5

Class 3000 Socket-Weld	1/4	3/8	1/2	3/4	1	1 1/4	1 1/2	2	2 1/2	3	4
	36-3/8	36-3/4	36-3/4	36-1 1/2	2 1/2-1 1/4	3 1/2-2	2 1/2-2	3 1/2-2 1/2	3 1/2-3	5-3 1/2	6-5
Class 6000 Socket-Weld	1/4	3/8	1/2	3/4	1	1 1/4	1 1/2	2	2 1/2	3	4
	36-1/4	36-3/8	36-3/4	36-1 1/4	2 1/2-1 1/4	4-1 1/2	2 1/2-2	3 1/2-2 1/2	5-3 1/2	5-4	8-6

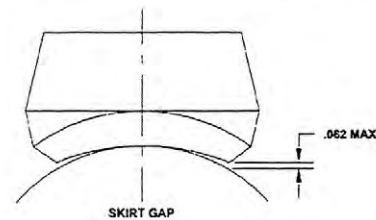
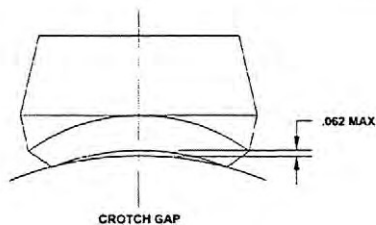

A large, empty rectangular box with a thin black border, occupying the majority of the page. It is intended for taking notes.



Blank area for notes.





**DODSON  
GLOBALINC**

**Atlanta (Corporate Office)**

5650 East Ponce de Leon Ave.  
Stone Mountain, GA 30083

t: 770-491-7333

f: 770-491-1590

toll free: 888-433-1433

**Denver**

4625 Forest Street  
Denver, CO 80216

t: 303-321-4722

f: 303-321-0186

toll free: 800-898-7124

**Cincinnati**

4061 Clough Woods Drive  
Batavia, OH 45103

**Star Systems**

t: 513-752-3211

f: 513-752-8094

toll free: 800-543-0700

**Ohio Valve**

t: 513-752-5600

f: 513-752-8267

toll free: 877-423-2660

**Houston**

175 Southbelt Industrial Dr.  
Houston, TX 77047

t: 713-433-7400

f: 713-433-6765

toll free: 888-433-1433

**New Jersey**

27 Cotters Lane  
East Brunswick, NJ 08816

t: 732-238-7001

f: 732-238-7760

toll free: 800-241-8682